

Brute Force Power Supply and 723 Regulator

Purpose:

Evaluate regulated and unregulated DC power supplies set to supply the same output voltage and compare their load regulation and ripple performance.

Equipment Required:

- 1 – Brute Force power supply and 723 Regulator board
- 1 – Transformers (120Vrms input, 1:10 and 1:20 outputs)
- 1 – Various load resistors, high power
- Digital Volt Meter and Oscilloscope

Pre-Lab:

- 1) Read all of lab first and review the lecture notes on discussing the inner workings and use of the 723 voltage regulator. Review the definitions of load regulation and ripple from lecture.
- 2) Predict the two AC outputs (Both V_{rms} and Voltage amplitude) of the transformers from the turn ratios given above assuming a 120Vrms line voltage input.
- 3) The signal from the transformer is rectified and filtered by the “brute force” power supply (BFPS) board. Predict the expected peak voltage to ground of the output of the rectifier for both transformer settings. Predict the ripple of the filter output of BFPS for a 12 ohm load. Assume C_{bulk} (see figure) is a 4.7mF filter capacitor and line input frequency of 60Hz. The marked TP connections are banana plugs connectors.

Lab:

Document your procedures (including drawing of the input, component, and probe connections) for characterizing the I/V behavior of both a brute force and a regulated DC supply, as well as other parameters. You will design the two power supplies to give the same output voltages (for small loads). FOR ALL STEPS, SHOW WORK AND DOCUMENT DATA WITH TABLES AND PLOTS, as appropriate. *Always keep transformer off when adjusting wires or connecting probes to the PCB.*

Most of the circuits are on a pre-fabricated printed circuit board (PCB) with sub-circuits that make up the regulated and unregulated circuits you will examine. There is also a 0.1 Ω current detect resistor on the PCB. See pspice layout and board layout of the PCB. The data sheet for the LM723 provides information on sizing of divider resistors. It can be found in print at each station or at <http://cache.national.com/ds/LM/LM723.pdf>.

- 1) Measure rms voltages of the two AC outputs of the transformers with a DVM. Do they match pre-lab predictions? Calculate the voltage peak to peak of the two AC outputs?
- 2) Get a PCB and test the BFPS with relatively high impedance load (250 ohm variable load resistor) connected to V_{bulk} . Connect up circuit to transformer. Measure V_{bulk} with DVM and the voltage ripple with the scope for BOTH transformer settings with a 250 ohm load.

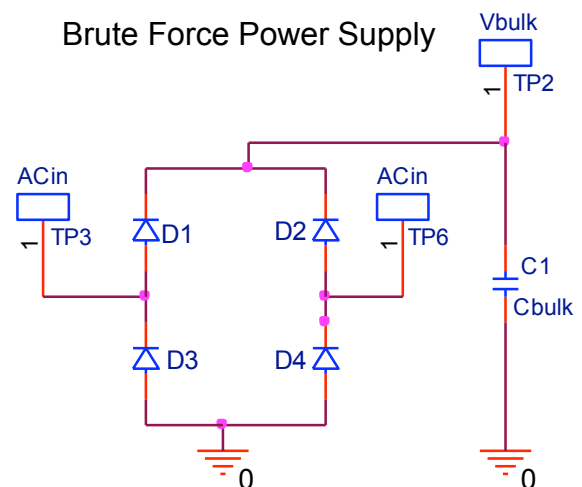

3) Use the lower (1:20) transformer voltage setting for this step. Set up the current sense resistor in series with the variable load resistance, with the current sense resistor nearer to ground. Vary load resistance from 250 ohms on down and as you do measure V_{bulk} and voltage across sense resistor with the DVM and V_{ripple} (peak to peak ripple voltage) with the scope. **Do not exceed 750mA output current (or fuse will blow).** Record a representative screen capture of the ripple at around 750mA.

Convert V_{ripple} into a percentage ripple. Record enough settings to get a smooth curve of V_{bulk} and percent ripple versus output current. Does percentage ripple curve match theory?

4) Connect up 723 power regulator. V_{bulk} is the input, V_{cc} . Choose resistors R_2 and R_3 that will make V_{reg} equal to maximum V_{bulk} you measured from 1:20 transformer setting. From data sheet, what is the minimum V_{cc} needed to run the LM723 regulator at this V_{reg} ? Why? Which transformer setting will you need to use get sufficient V_{cc} ? Set up regulator with chosen R_2 and R_3 and proper transformer setting. Again have load include the 0.1 ohm current sense resistor and use DVM to alternate between measuring V_{reg} and voltage across current sense resistor. Vary load resistance from 250 ohms on down. **Do not exceed 700mA output current or go below 2 Vdc output voltages.**

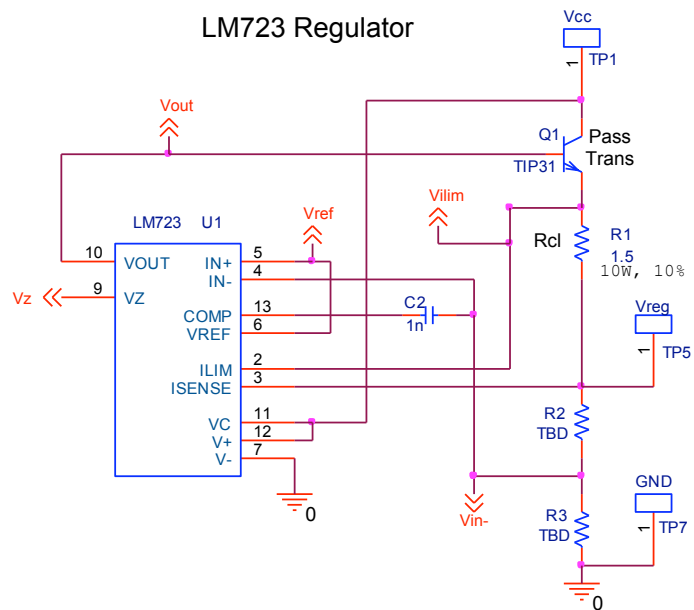

Use scope measure peak to peak voltage of ripples of V_{reg} and V_{cc} . Record enough settings to get a smooth curve of V_{bulk} and V_{ripple} versus output current. What would you estimate the minimum ripple rejection to be (in dB)? Is your estimate consistent with the specifications for 723?

5) Measure V_{ref} and compare with specifications sheet.

6) What is V_{reg} and V_{out} for 250mA load current? Does that make sense?

7) Based on the value specified for R_1 (R_{cl}) in the schematic above, what is the expected current limit for this regulator?

Conclusion:

1. Compute normalized voltage outputs for both the BFPS and the 723 regulated circuits, where $v_{norm} = v_{out} / v_{max}$. Plot on one graph, two curves: the normalized voltage of 723 versus actual current output of 723 and the normalized voltage of BFPS versus actual current output of BFPS. Comment on these two curves.
2. On a second graph, plot the measured percentage AC ripples as a function of output current for both supplies.
3. Compare and contrast the two supplies.