

Today

Displays, Memory and Microprocessors

- **Review logic gates, discuss decoders, LED displays**
- **Flip flops and their applications**
- **Microprocessors (in 1 slide)**
- **Arduino microcontroller**

Review of Logic Gates

Schematic symbol

Algebraic example

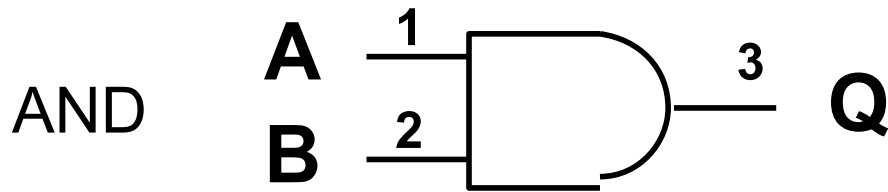

$$Q = A \cdot B$$

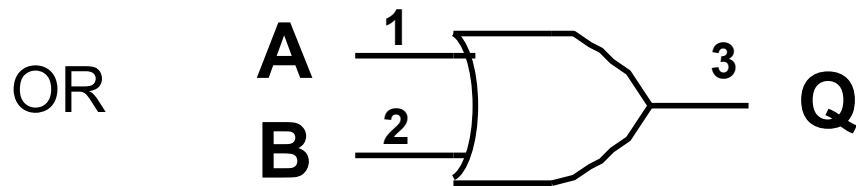

$$Q = A + B$$

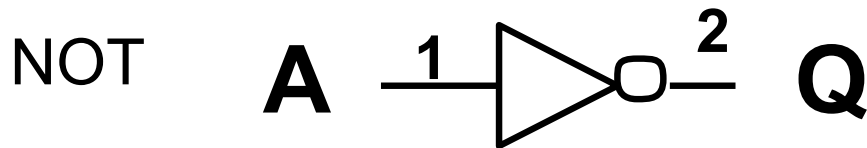

$$Q = \overline{A}$$

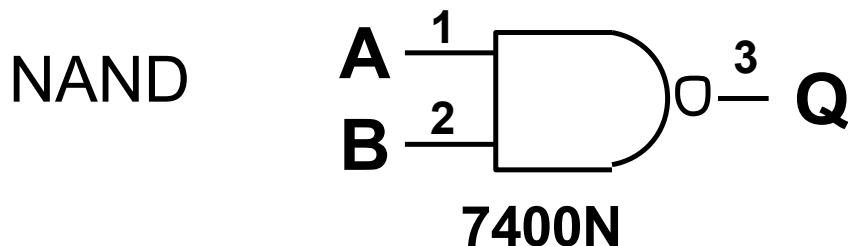

$$\overline{A \cdot B} = Q$$

Things made from gates:

Adder: A digital circuit that adds two binary numbers.

Multiplexer: Connects a “bus” (bundle of wires) to an “address” specified by a binary number.

Decoder: Uses logic to translate one pattern of bits to another, related pattern of bits.

Anything that looks like a TRUTH TABLE.

7-Segment LED Display

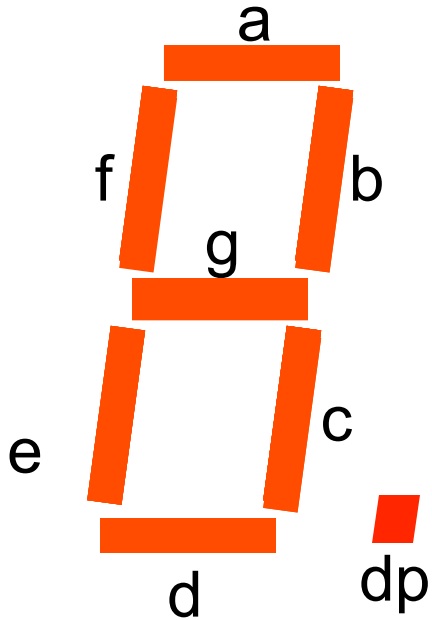

Connected to +5V
COMMON ANODE

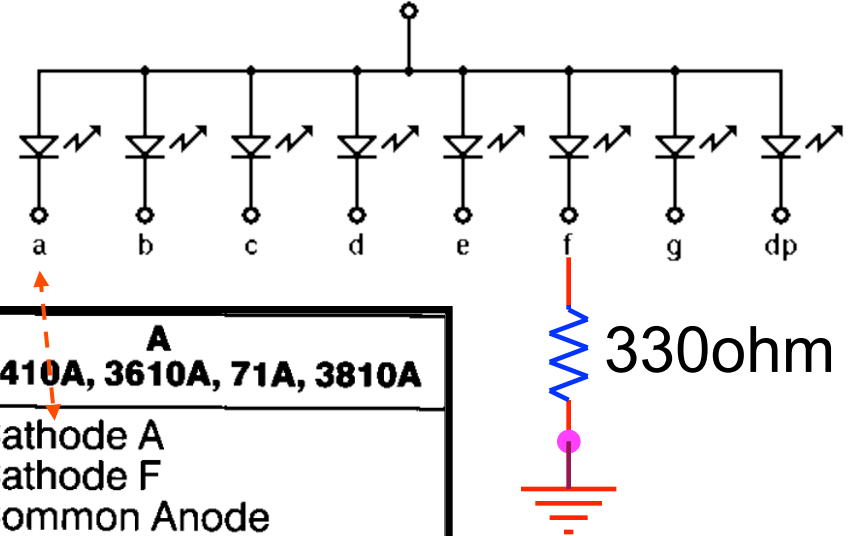

Pin No.	A MAN3410A, 3610A, 71A, 3810A
1	Cathode A
2	Cathode F
3	Common Anode
4	No Pin
5	No Pin
6	No Connection
7	Cathode E
8	Cathode D
9	Cathode D.P.
10	Cathode C
11	Cathode G
12	No Pin
13	Cathode B
14	Common Anode

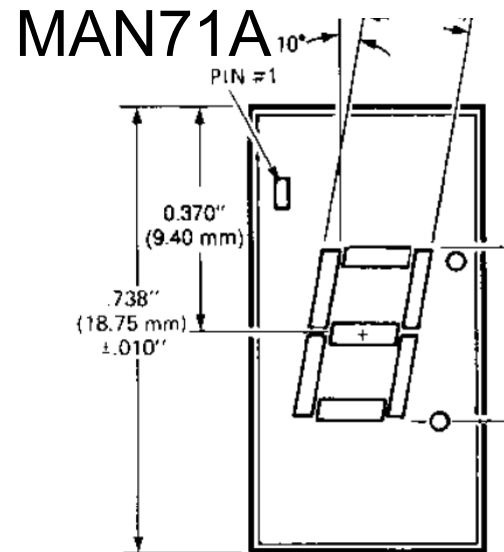

BCD

Binary Coded Decimal maps a four bit binary code directly to decimal numbers.

Great for using binary to provide the human interface, but is really inefficient binary “packing” so is rarely used internally in circuits.

Chips are available that perform the conversion binary \rightarrow BCD \rightarrow binary.

A ₃	A ₂	A ₁	A ₀	Dec
0	0	0	0	0
0	0	0	1	1
0	0	1	0	2
0	0	1	1	3
0	1	0	0	4
0	1	0	1	5
0	1	1	0	6
0	1	1	1	7
1	0	0	0	8
1	0	0	1	9
1	0	1	0	Undef
...	Undef
1	1	1	1	Undef

BCD Decoder-Driver

Logic Symbol

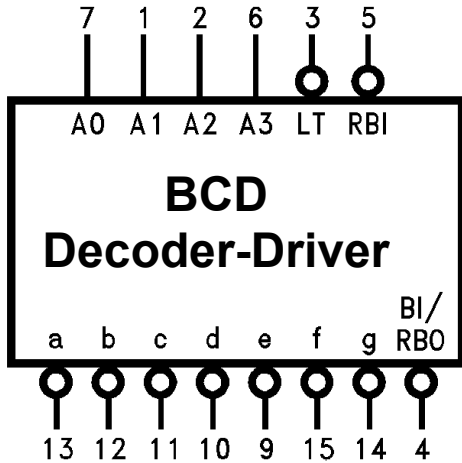

V_{CC} = Pin 16
GND = Pin 8

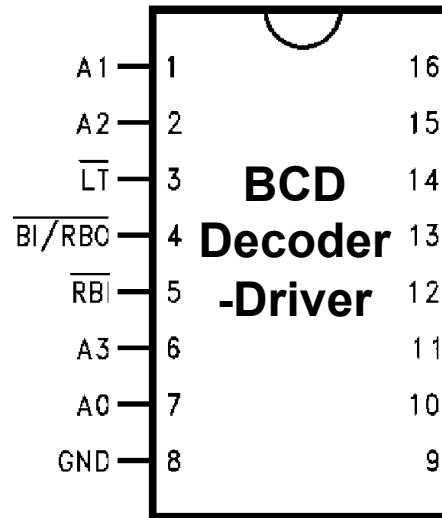
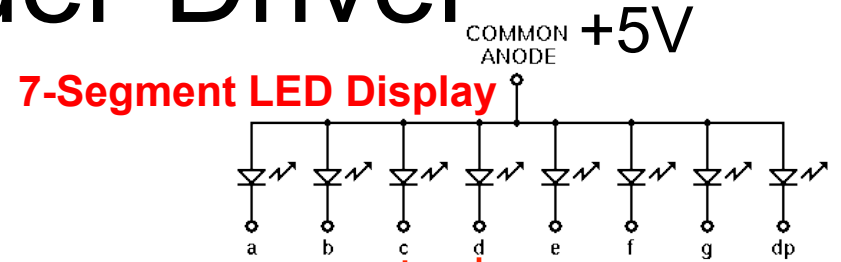

330ohm
...
An LED is on when chip output goes low.

Numerical Designations—Resultant Displays

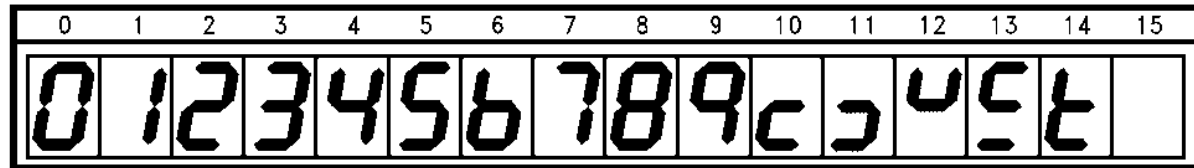

7-Segment LED Display

Truth Table - BCD Decoder

DM74LS47

Truth Table															
Decimal or Function	Inputs							Outputs						Note	
	$\overline{\text{LT}}$	$\overline{\text{RBI}}$	A3	A2	A1	A0	$\overline{\text{BI/RBO}}$	$\overline{\text{a}}$	$\overline{\text{b}}$	$\overline{\text{c}}$	$\overline{\text{d}}$	$\overline{\text{e}}$	$\overline{\text{f}}$		$\overline{\text{g}}$
0	H	H	L	L	L	L	H	L	L	L	L	L	L	H	(Note 2)
1	H	X	L	L	L	H	H	H	L	L	H	H	H	H	(Note 2)
2	H	X	L	L	H	L	H	L	L	H	L	L	H	L	
3	H	X	L	L	H	H	H	L	L	L	L	H	H	L	
4	H	X	L	H	L	L	H	H	L	L	H	H	L	L	
5	H	X	L	H	L	H	H	L	H	L	L	H	L	L	
6	H	X	L	H	H	L	H	H	H	L	L	L	L	L	
7	H	X	L	H	H	H	H	L	L	L	H	H	H	H	
8	H	X	H	L	L	L	H	L	L	L	L	L	L	L	
9	H	X	H	L	L	H	H	L	L	L	H	H	L	L	
10	H	X	H	L	H	L	H	H	H	H	L	L	H	L	
11	H	X	H	L	H	H	H	H	H	L	L	H	H	L	
12	H	X	H	H	L	L	H	H	L	H	H	H	L	L	
13	H	X	H	H	L	H	H	L	H	H	L	H	L	L	
14	H	X	H	H	H	L	H	H	H	H	L	L	L	L	
15	H	X	H	H	H	H	H	H	H	H	H	H	H	H	
$\overline{\text{BI}}$	X	X	X	X	X	X	L	H	H	H	H	H	H	H	(Note 3)
$\overline{\text{RBI}}$	H	L	L	L	L	L	L	H	H	H	H	H	H	H	(Note 4)
$\overline{\text{LT}}$	L	X	X	X	X	X	H	L	L	L	L	L	L	L	(Note 5)

Combinational versus Sequential

Combinational logic:

Output state of the circuit depends only on the present input states.

Can be described by a truth table.

Sequential Logic:

Output state depends on both the present input states *and* on previous history.

A Sequential Logic circuit has memory!

RS Flip-Flop

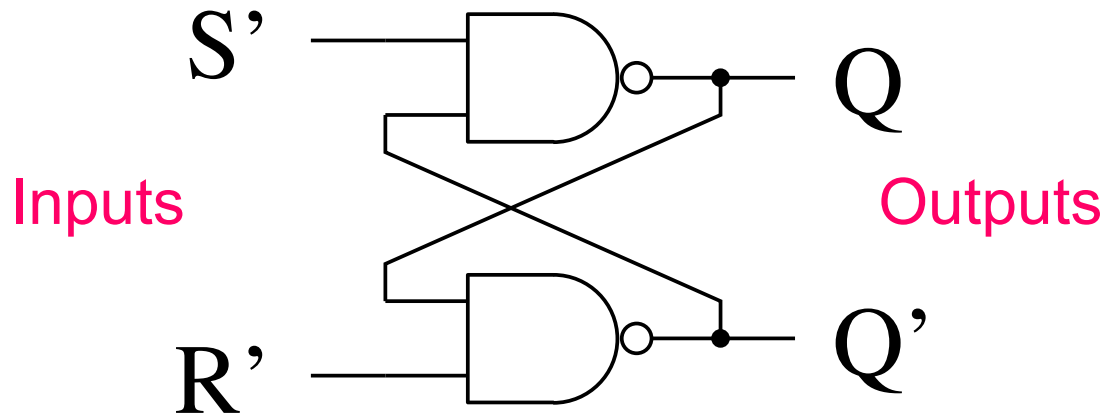

normally $S' = 1$ and $R' = 1$

$$\textit{then } Q_1 = \overline{S' \cdot Q'_0} = \overline{Q'_0}$$

$$\textit{and } Q'_1 = \overline{R' \cdot Q_0} = \overline{Q_0}$$

The state only changes when one of the inputs (R or S, but not both) are briefly toggled low (FALSE).

State Table for RS FF

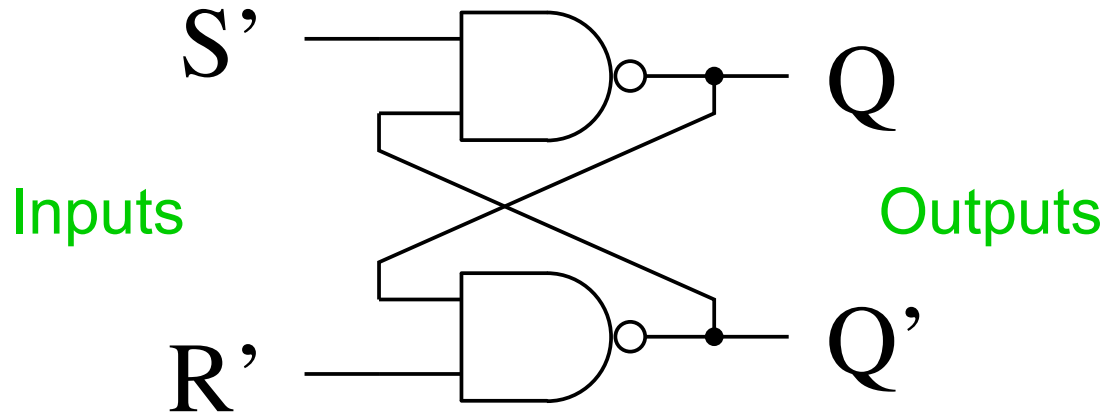

R'	S'	Q	Q'
1	1	1/0	0/1
0	1	0	1
1	0	1	0
0	0	1	1

A transition to any of these three states results in a definite output.

State Table for RS FF

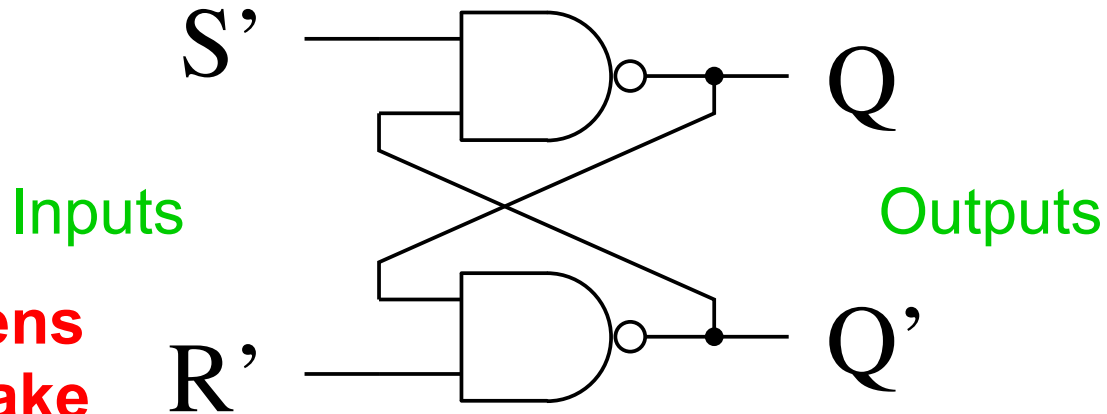

What happens when we make this transition?

R'	S'	Q	Q'
1	1	1/0	0/1
0	1	0	1
1	0	1	0
0	0	1	1

State Table for RS FF

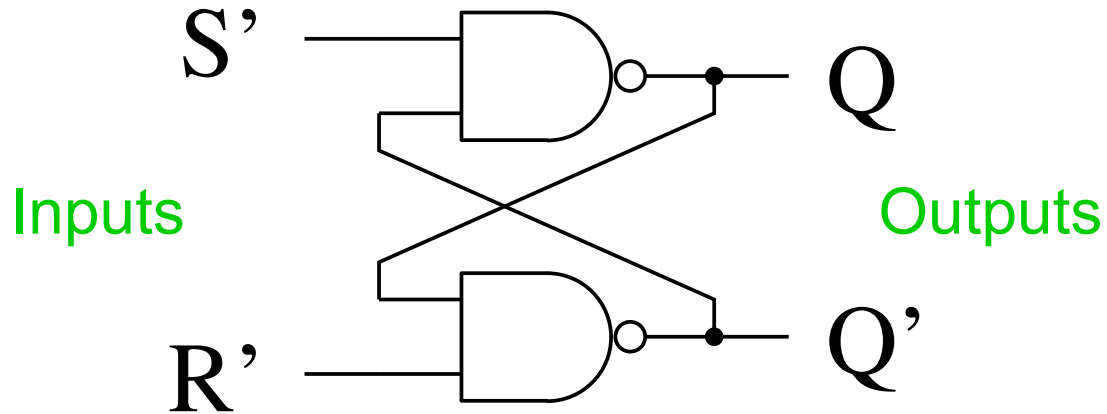

Or either of these?

R'	S'	Q	Q'
1	1	1/0	0/1
0	1	0	1
1	0	1	0
0	0	1	1

Things you can make from flip-flops

Register: Storage within a microprocessor for a “word” of 1 or more bytes.

Address pointer: A register that is used to specify an address to a multiplexer. The result is an “address bus”.

Counter: A sequence of bits representing a binary number that increments (or decrements) in response to a clock signal.

Clocked Flip-Flop: Divide by 2

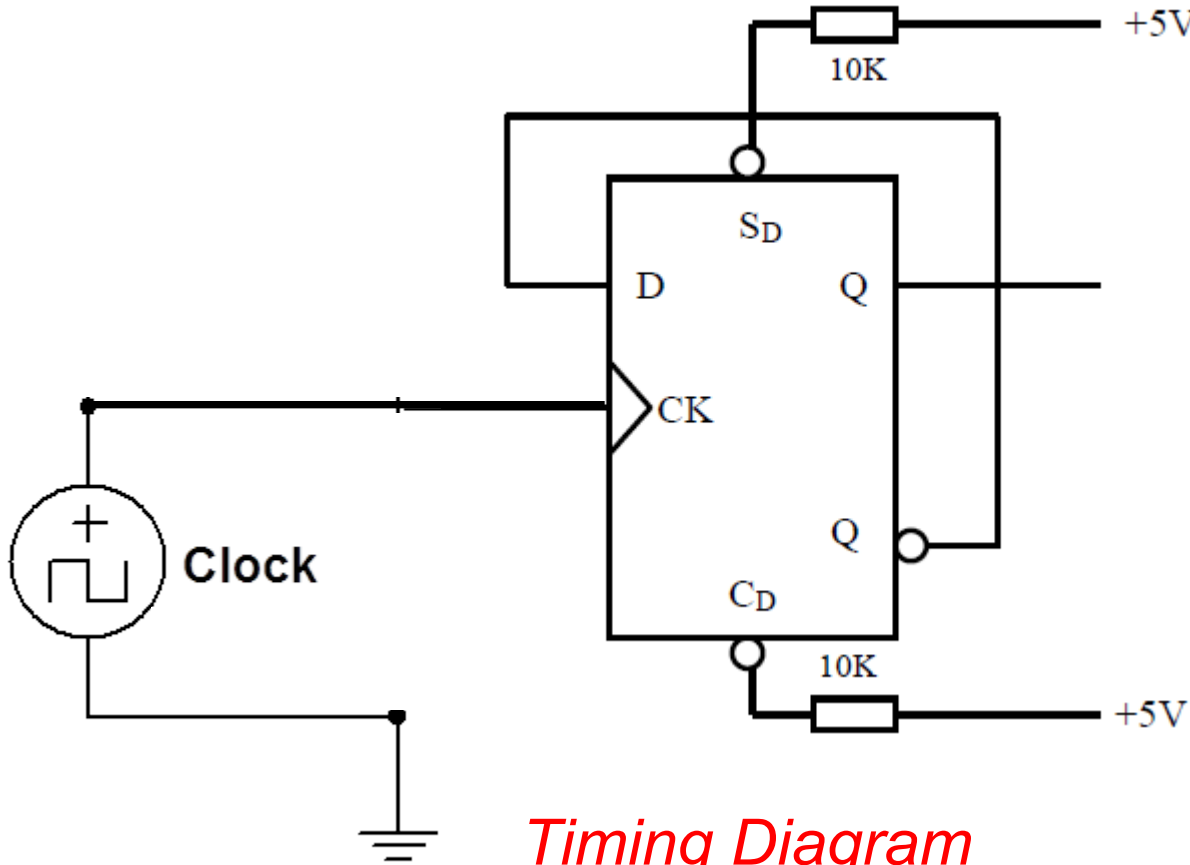

Toggle-Connected Flip-Flop

4013 is a CMOS D-type clocked FF, positive edge triggered. This device from Multisim labels the reset pin as C for “clear.”

Timing Diagram

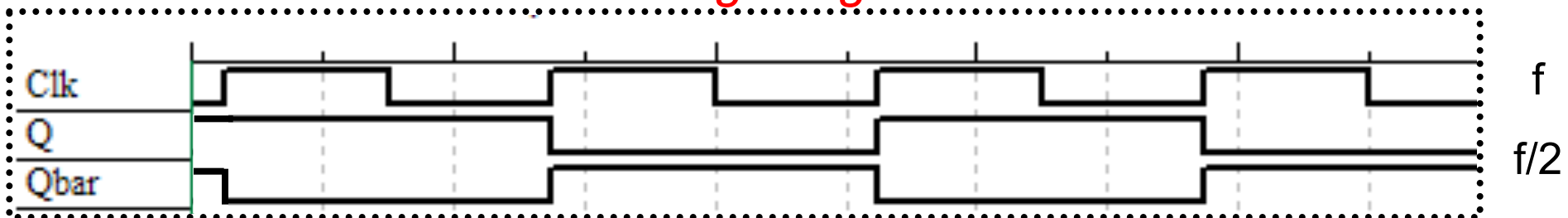

Ripple Counter

Clock plus
n flip-flops

Divided by 2

Divided by 2^n

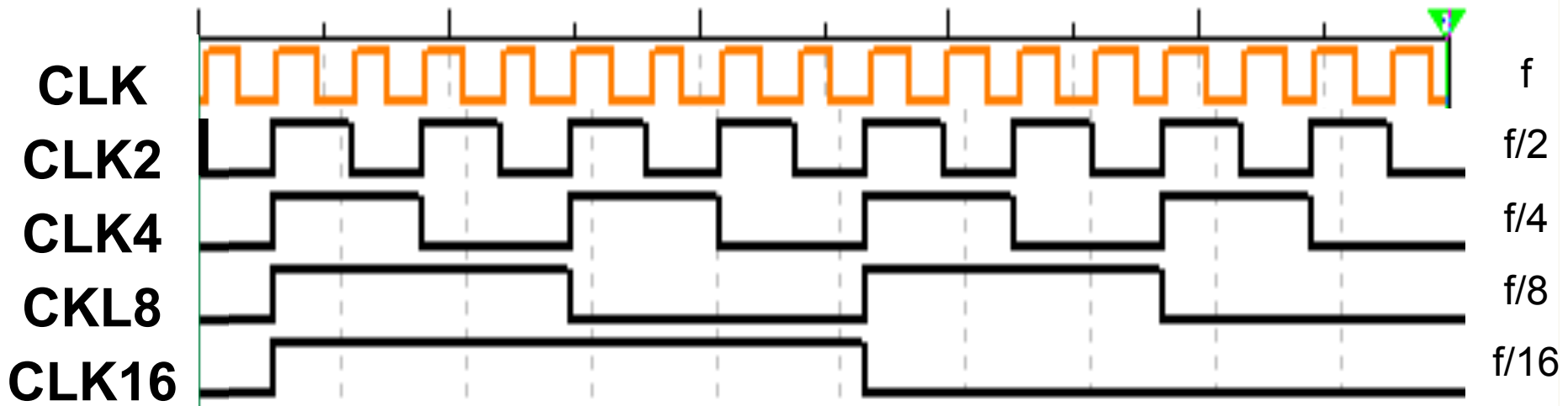
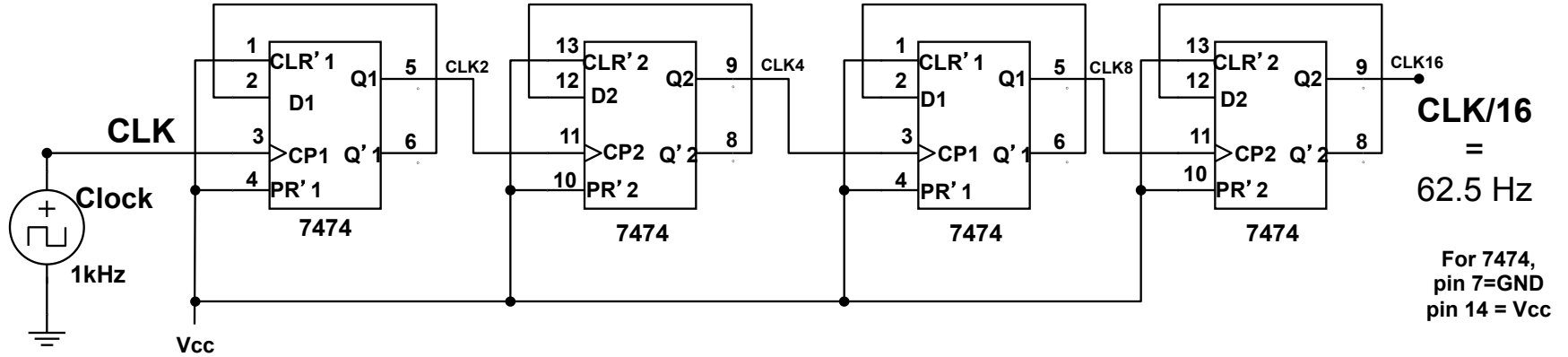

Microprocessors

MCS8650x Internal Architecture

This is the 6502 microprocessor that I learned to program in High School.

You don't need to understand the innards to use it!

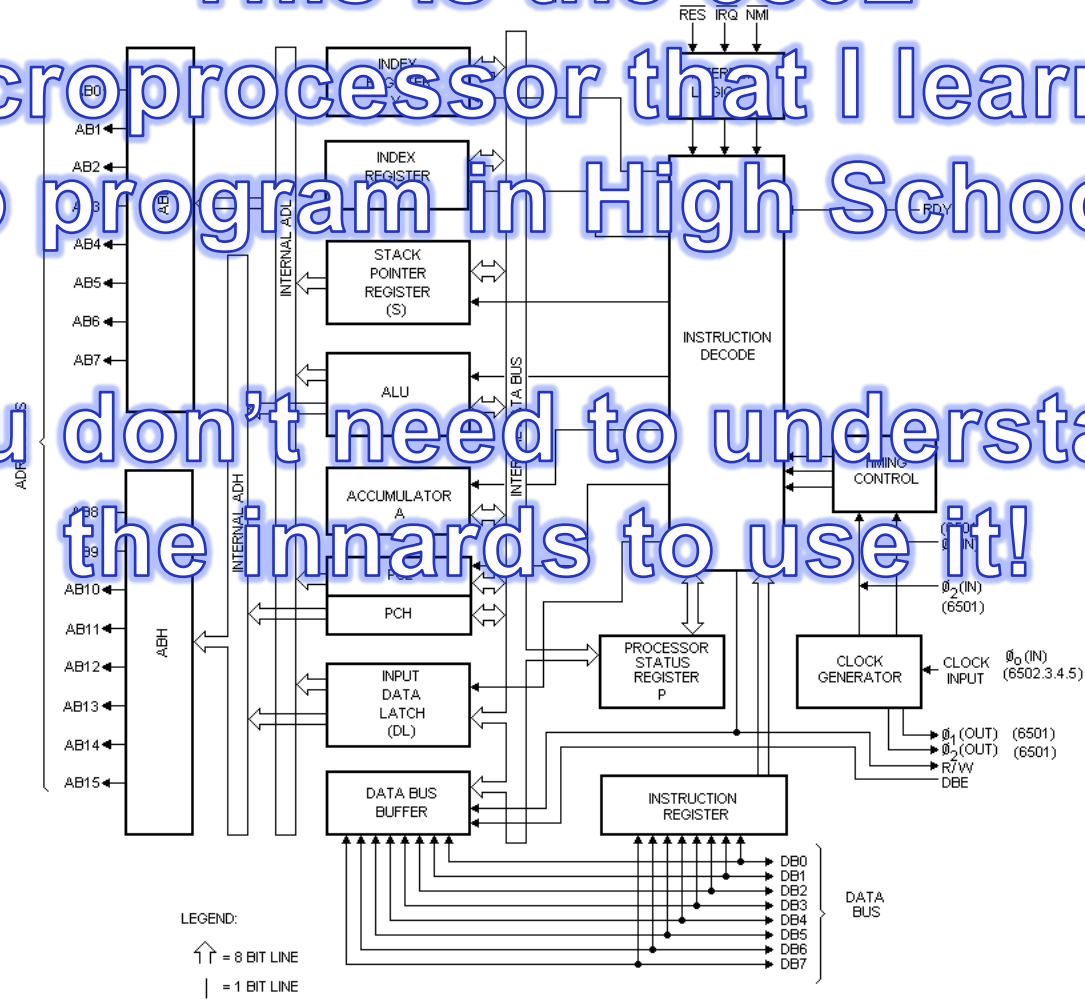

NOTE: 1. CLOCK GENERATOR IS NOT INCLUDED ON MCS8501
2. ADDRESSING CAPABILITY AND CONTROL OPTIONS VARY WITH EACH OF THE MCS850X PRODUCTS

Arduino

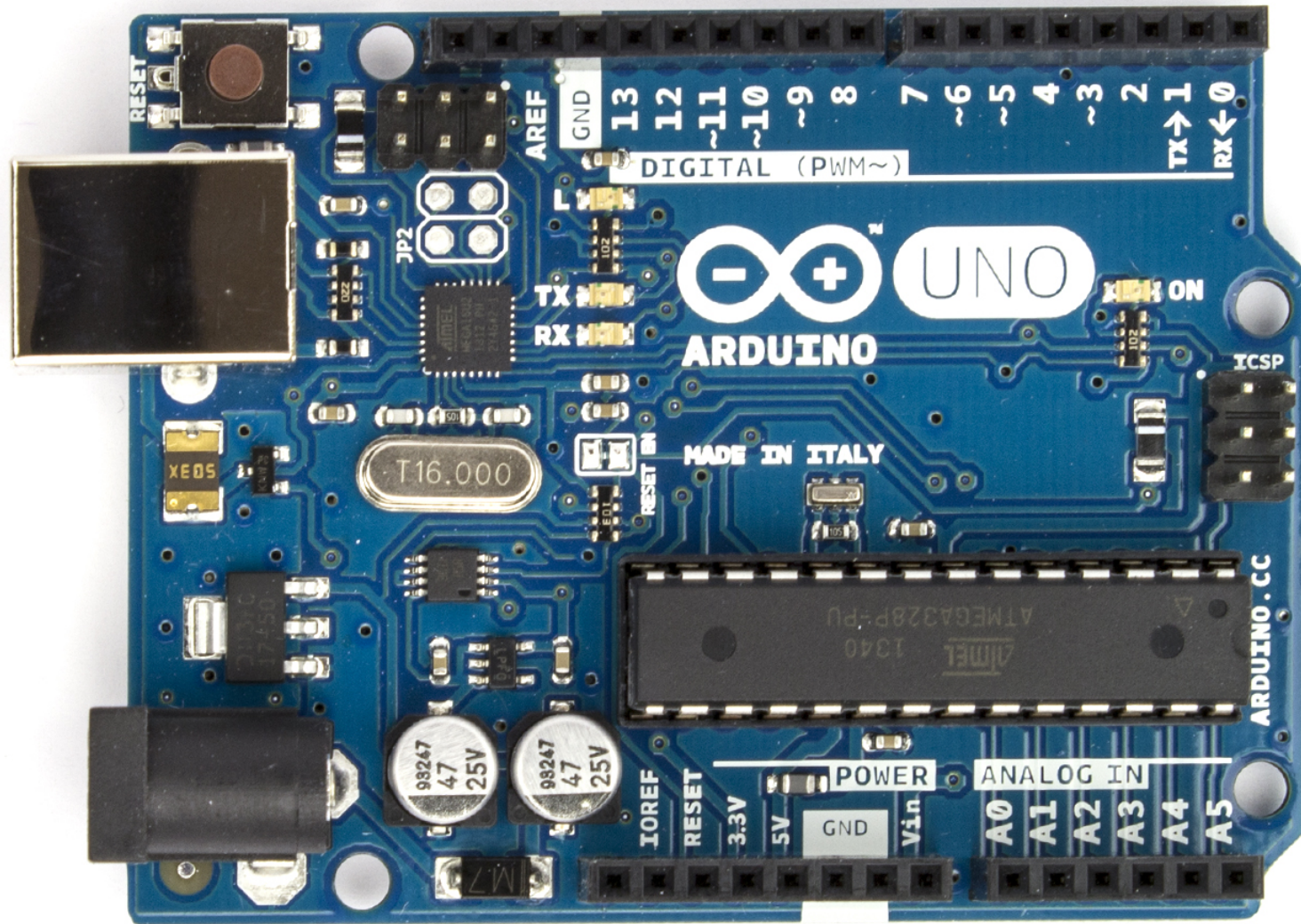

Arduino

Arduino home page:

<http://www.arduino.cc>

Arduino language reference:

[http://arduino.cc/en/Reference/
HomePage](http://arduino.cc/en/Reference/HomePage)

Arduino examples:

<http://arduino.cc/en/Tutorial/HomePage>