

Today

Lecture 1 Physics 262 Laboratory Electronics II 1/18/11

- **Go over course schedule and expectations**
- **Lecture**
 - Review circuit elements and linear circuits and their response to stimuli
 - Frequency response and complex analysis of circuit elements
 - Intro to complex voltage divider and Decibals
- **Homework**
 - **HW1:**
 - Horowitz and Hill: Exercises 1.1 (p.6), 1.2 (p.6), 1.3 (p. 6), 1.5 (p. 7), 1.10(p.13), 1.11(p.17), 1.12(p. 23), 1.15(P.27), and 1.17 (p. 33) (Mostly review)
 - Email me from your preferred email address (counts as quiz point)
 - Email me if you can't make project presentation time (Friday 4/29/11 2-4pm)
 - All due Tuesday 1/25/11
 - Homework problems are NOT turned in (but I advice you do it!)
- **Reading in Horowitz and Hill**
 - Scan pages 1-28 in H&H by 1/20/10 (make sure you understand these 261 concepts)
 - Read pages 29-42 in H&H by 1/20/10
- **Lab this week**
 - Lab 1: Complex Impedance. Lab handout
 - Prelab due Thursday at start of lab.

Introduction

Spring 2011

Physics 262 Laboratory Electronics II

- **Instructor – Randy Babbitt**

Physics Office: EPS 210, 994-6156 (EPS)

Spectrum Lab Office: 994-1797

Cell: 539-9751

Email: Babbitt_teaching2011@physics.montana.edu

**Office hours –Tuesdays 1:00-2:00 and Thursdays 12:00-12:50
or by appointment (just email or call me)**

- **Teaching Assistant – Harsh Bhatkar**

Physics office: EPS 226

Email: [Harsh \[bhatkar@physics.montana.edu\]](mailto:Harsh [bhatkar@physics.montana.edu])

Office hours: Thursdays 1-2 and Fridays 11-12

- **Lectures: Tuesdays 9-9:50 in Roberts 121**

- **Lab: Thursdays 8:00-10:50 or 2:10-5:00pm in EPS 228**

- **Final: Monday May 2, 2010 12-2pm in Roberts 121**

Requirements

Prerequisite:

Phsx 261, Laboratory Electronics I

Required texts:

“The Art of Electronics”, Horowitz and Hill, 2nd Edition

Reference text:

“The Analysis and Design of Linear Circuits”, Thomas/Rosa

Two lab notebooks required:

Roaring Spring brand #77108 5x5 quadrille lab books, sewn binding or equivalent

-Two notebooks are to be rotated with alternating labs

Web Site

- Course web site

www.physics.montana.edu/faculty/babbitt/Physics262/phsx262.html

- Homework and Reading Assignments
- Schedule and Important Dates
- Lab Instructions
- Handouts
- Project Description, write ups, and due dates.
- Lectures and Lecture Notes

Course Policies

- **Laboratory exercises are a critical part of this course**
 - If you must miss a lab, you must schedule makeup time **IN ADVANCE**
 - You must get 50% or better on all labs to pass course
- **HW1: Send me your email address (via my email address)**
 - So I can contact you with additional course information and schedule/assignment/due date changes.
- **Check web often**
 - Important Date/Schedule/Assignment changes and hints on web
- **Lab Notebooks due in Friday 10am one week after lab.**
 - Will be returned next Tuesday in class or in lab on Thursday.
 - A Late Lab Notebook will have 20% penalty subtracted.
- **Ethical behavior is expected**
 - Sign and return cheating policy
 - Individual lab write-ups based on two person lab teams.
 - All other work is individual, unless specifically stated.

Homework and Quizzes

- Homework “due” each Tuesday
 - Homework is NOT turned in.
 - Due date reflects day a quiz or exam may be given that has similar problems on it.
- You can work together on homework.
- Ask questions in lab and office hours.

- Quizzes are quasi-weekly
 - Short quiz at end of class/beginning of lab
- Quizzes are easy if you do the homework problems (tightly based on HW problems)
- Quizzes are open book/notes and your HW (no copies)

Grading

<u>Evaluation Method</u>	<u>Weight (%)</u>
Lab Journal	45
Final Project	15
Quizzes/Worksheets	15
Final Exam	25

Laboratory Exercises

- Pre-Lab exercises (up to 20% of lab grade)
 - Pre-Lab and Lab exercises will be handed out during Tuesday lecture
 - Pre-lab due at start of lab on Thursday
 - Pre-lab will be checked by TA at start of lab.
 - It is your responsibility to make sure he checks you pre-lab at start of lab.
- Lab write-ups (45% of course grade)
 - Use two lab books (turn in alternating weeks, see lab schedule)
 - You must get 50% on ALL labs to pass course.
 - Lab write-up format and scoring rubric: See lecture from first lab
 - Work in pairs (but separate lab notebooks/write-ups)
 - Record your combined work in both your lab books
 - Division of labor is a good thing. Shows good lab skills.
 - HOWEVER, you must understand the work done by your partner.
 - Okay to copy partner's data/graphs, but not their analysis/conclusions.
 - Your conclusions must be your own, in your own words.

Semester Project

- Several weeks devoted to the project (15% of course grade)
 - Project incorporates many concepts/activities of regular lab exercises.
 - Common problem but with different approaches
 - Developing a laser light show circuit driver
 - Use a single one of your lab notebooks for project (see lab schedule)
- Work in pairs (but separate lab notebooks/write-ups)
 - Record your work in both your lab books
 - Division of labor is a good thing. Shows good lab skills.
 - Record joint work in both of your lab books.
 - Okay to copy partner's data/charts
but not their reduction/conclusions from data.
 - Reference others work with proper acknowledgement in your lab book
 - Tape printed/copied pages neatly into your journal as needed
 - No loose papers. No loose edges. Tape all four corners. Okay to tape rotated.
- Project presentation time is a public light show driven by your circuits
 - Tentatively Friday April 29, 2011 2:00PM-4:00pm
 - You must email me by 1/25/10 if you can't make this presentation time!!!!
- More details later and on web site.

Resistors

$$i(t) = \frac{v(t)}{R}$$

$$R_{\text{Series}} = R_1 + R_2$$

$$\frac{1}{R_{\text{Parallel}}} = \frac{1}{R_1} + \frac{1}{R_2}$$

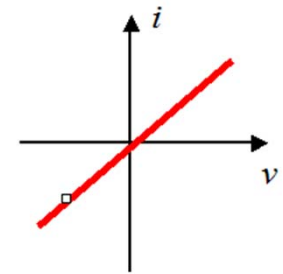
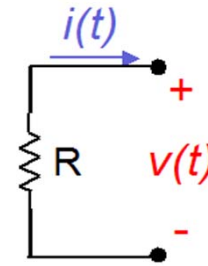

Resistor constraint independent of DC or AC circuit

- Voltage changes instantaneously with current

Resistor provides resistance to current flow

- Introduces instant voltage drop in response to current

Capacitors

$$\begin{array}{l} \boxed{Q = CV} \\ \boxed{I = \frac{dQ}{dt}} \end{array} \rightarrow \boxed{i_c(t) = C \frac{dv_c(t)}{dt}}$$

$$\frac{1}{C_{\text{Series}}} = \frac{1}{C_1} + \frac{1}{C_2}$$

$$C_{\text{Parallel}} = C_1 + C_2$$

- Capacitor response depends on changes in voltage

- Capacitor reacts to a voltage change with current

- At DC, the capacitor looks like an open circuit.

$$\text{if } dv_c(t)/dt = 0 \text{ then } i_c(t) = 0$$

- Capacitor voltage cannot change instantaneously

$$\text{if } dv_c(t)/dt = \infty \text{ then } i_c(t) = \infty$$

Inductors

$$v_L(t) = L \frac{di_L(t)}{dt}$$

$$L_{\text{Series}} = L_1 + L_2$$

$$\frac{1}{L_{\text{Parallel}}} = \frac{1}{L_1} + \frac{1}{L_2}$$

- Inductor response depends on changes in current

- Inductor reacts to a current change with voltage

- At DC, the inductor looks like a short circuit.

$$\text{if } di_L(t)/dt = 0 \text{ then } v_L(t) = 0$$

- Inductor current cannot change instantaneously

$$\text{if } di_c(t)/dt = \infty \text{ then } v_c(t) = \infty$$

RC Circuit

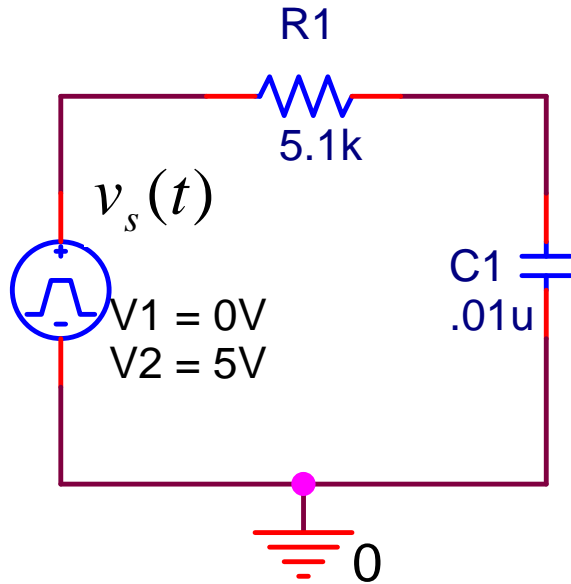

$$v_s(t) = v_{R_1}(t) + v_{C_1}(t) \quad i_{R_1}(t) = i_{C_1}(t)$$

$$i_c(t) = C \frac{dv_{C_1}(t)}{dt} \quad v_{R_1}(t) = R_1 i_{R_1}(t)$$

$$v_s(t) = R_1 i_c(t) + v_{C_1}(t)$$

$$= R_1 C_1 \frac{dv_{C_1}(t)}{dt} + v_{C_1}(t)$$

This suggests an exponential solution.

General RC Response

(Natural and Forced Responses)

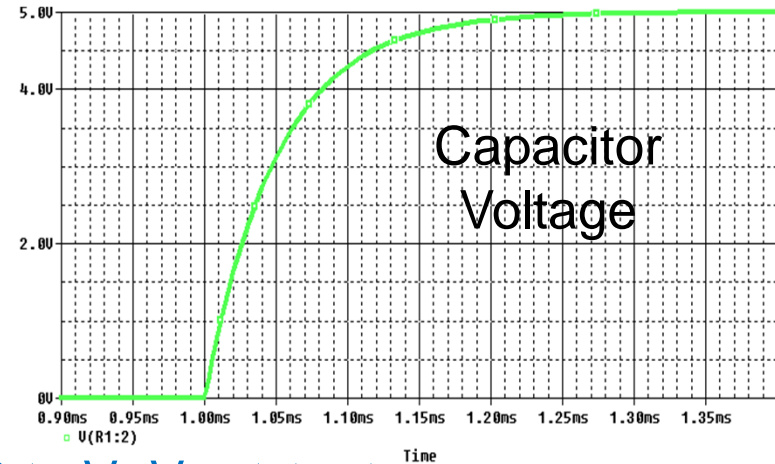
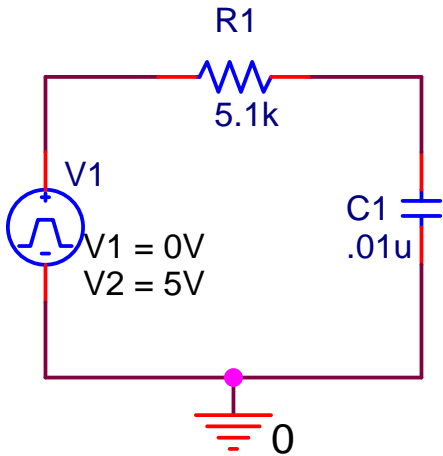

Response to step function voltage from $V=0$ to $V=V_0$ at $t = t_0$

$$v_C(t) = \left[v_s(t < t_0) - v_s(t > t_0) \right] e^{-t/RC} + v_s(t > t_0)$$

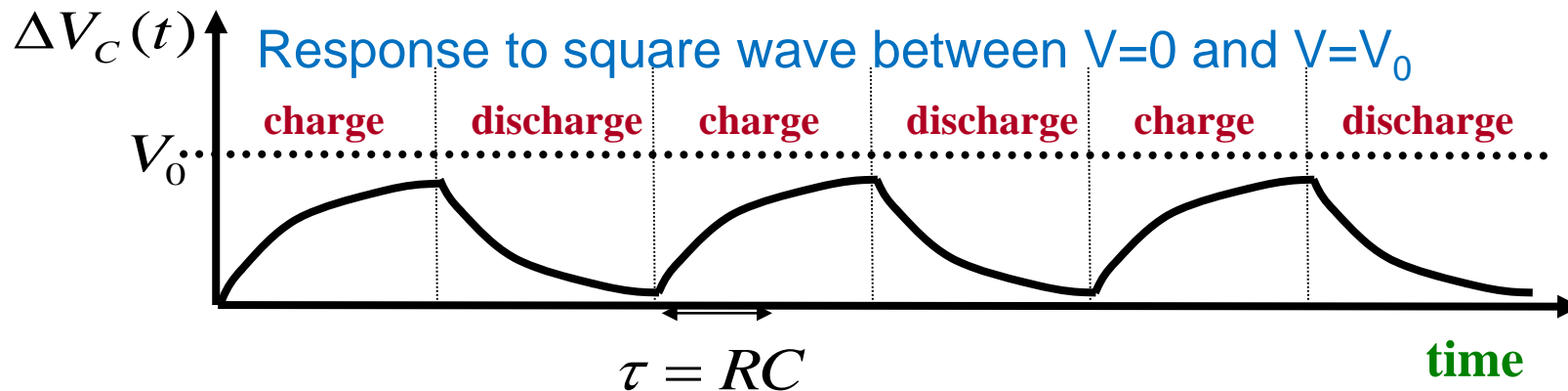

Let's analyze RLC Circuit

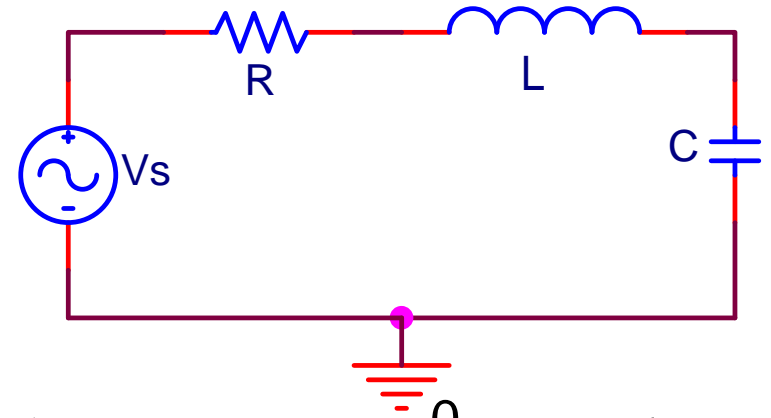

$$v_S(t) = v_R(t) + v_L(t) + v_C(t)$$

$$v_R(t) = RC \frac{dv_C(t)}{dt}$$

$$v_L(t) = L \frac{di_L(t)}{dt}$$

$$i_C(t) = C \frac{dv_C(t)}{dt}$$

$$v_L(t) = L \frac{d}{dt} \left(C \frac{dv_C(t)}{dt} \right) = LC \frac{d^2 v_C(t)}{dt^2}$$

$$v_S(t) = LC \frac{d^2 v_C(t)}{dt^2} + RC \frac{dv_C(t)}{dt} + v_C(t)$$

-
-
-

THERE MUST BE A BETTER WAY!!!!

Ordinary Differential Equation Solutions to Circuit Response

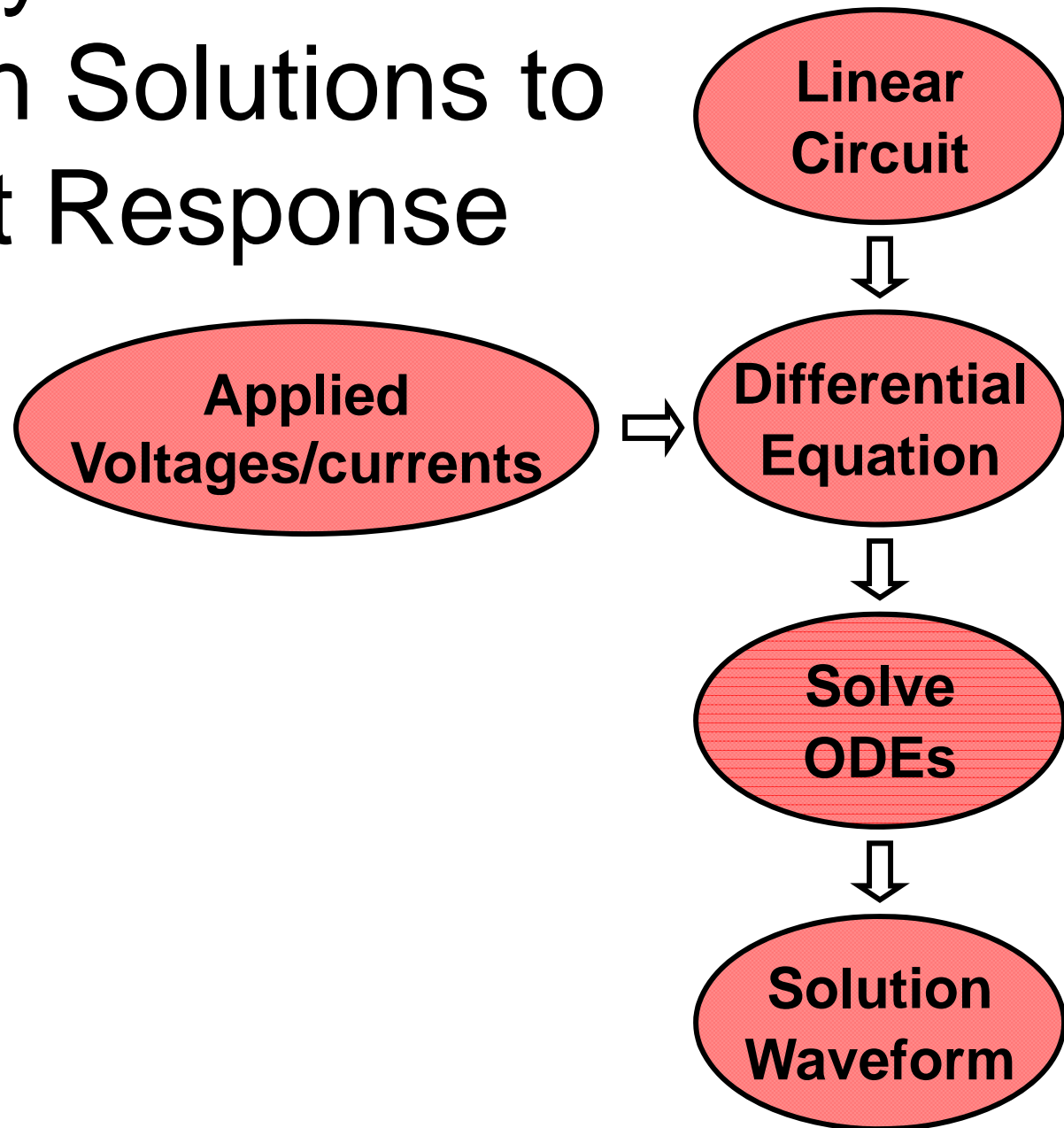

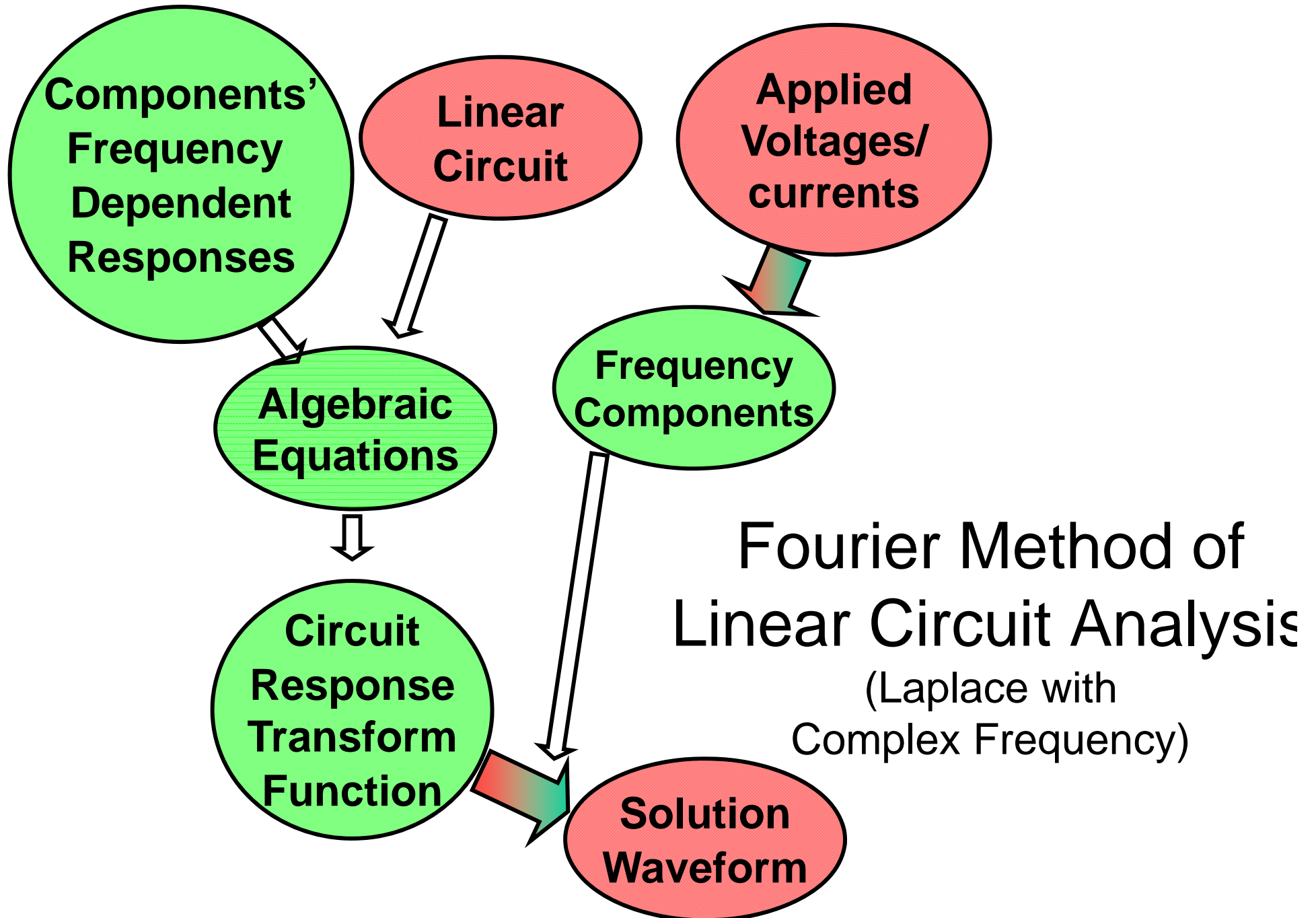

Linear Circuits

- In a linear circuit, the response, $O(t)$ to a sum of inputs, $A(t)$ & $B(t)$, is the sum of the individual responses
 - IF $A_{in}(t) \Rightarrow O_A(t)$ $B_{in}(t) \Rightarrow O_B(t)$
 - THEN $A_{in}(t) + B_{in}(t) \Rightarrow O_A(t) + O_B(t)$
- In a linear circuit, if the input is a sinewave at frequency f , the output will also be *sinusoidal* at frequency f

The phase and amplitude of the output may vary, but not the frequency.
- Any input can be decomposed into a sum of sinusoidal inputs, whose responses can be determined in a linear circuit analysis, and the output is the sum of these sinusoidal responses.

Frequency Decomposition is Fourier Analysis

Show excel demo

Complex Representation of Voltages and Currents

$$V(t) = V(\omega) \cos(2\pi ft + \varphi(\omega))$$

$$= V(\omega) \cos(\omega t + \varphi(\omega))$$

$$= \operatorname{Re} \left\{ V(\omega) \cos(\omega t + \varphi) + jV(\omega) \sin(\omega t + \varphi(\omega)) \right\}$$

$$= \operatorname{Re} \left\{ V(\omega) \exp(j(\omega t + \varphi(\omega))) \right\}$$

$$= \operatorname{Re} \left\{ V(\omega) e^{j\varphi(\omega)} e^{j\omega t} \right\}$$

$$= \operatorname{Re} \left\{ \tilde{V}(\omega) e^{j\omega t} \right\}$$

In general, $V(t)$ is sum of sinusoidal inputs, but we can analyze them one at a time.

Complex Representation of $V(t)$

$$\tilde{V}(\omega) = V(\omega) e^{j\varphi(\omega)}$$

Complex Representation of Voltages and Currents

$$\tilde{V}(\omega) = V(\omega)e^{j\phi(\omega)}$$

The real and imaginary parts represent the cosine and sine components of the voltage

$$\begin{aligned} V(t) &= \operatorname{Re} \left\{ \tilde{V}(\omega) e^{j\omega t} \right\} \\ &= \operatorname{Re} \left\{ \tilde{V}(\omega) \right\} \cos(\omega t) - \operatorname{Im} \left\{ \tilde{V}(\omega) \right\} \sin(\omega t) \end{aligned}$$

Current also becomes complex

$$\begin{aligned} i(t) &= \operatorname{Re} \left\{ \tilde{i}(\omega) e^{j\omega t} \right\} \\ &= \operatorname{Re} \left\{ \tilde{i}(\omega) \right\} \cos(\omega t) - \operatorname{Im} \left\{ \tilde{i}(\omega) \right\} \sin(\omega t) \end{aligned}$$

Useful relationship

If you three complex numbers represented as:

$$\tilde{A} = Ae^{j\varphi_A}$$

$$\tilde{B} = Be^{j\varphi_B}$$

$$\tilde{X} = Xe^{j\varphi_X}$$

Then if

$$\tilde{X} = \tilde{A}\tilde{B}$$

The magnitudes and phases are related by

$$X = AB \quad \varphi_X = \varphi_A + \varphi_B$$

Impedance of Capacitor

$$V(t) = \operatorname{Re}\{\tilde{V}(\omega)e^{j\omega t}\} \quad \text{For a sinusoidal input}$$
$$= V(\omega)\cos(\omega t + \varphi)$$

$$i(t) = C \frac{dV(t)}{dt}$$
$$= -\omega CV(\omega)\sin(\omega t + \varphi)$$

$$= \operatorname{Re}\left\{\frac{V(\omega)e^{j\varphi}e^{j\omega t}}{(1/j\omega C)}\right\}$$

$$= \operatorname{Re}\left\{\frac{\tilde{V}(\omega)e^{j\omega t}}{Z_C(\omega)}\right\}$$

if $i(t) = \operatorname{Re}\{\tilde{i}(\omega)e^{j\omega t}\}$

then $\tilde{i}(\omega) = \frac{\tilde{V}(\omega)}{Z_C(\omega)}$

where

$$Z_C(\omega) = \frac{1}{j\omega C} = \frac{1}{\omega C}e^{-i(\pi/2)}$$

Impedance and Ohm's Law

Resistor

$$Z_R(\omega) = R$$

Capacitor

$$Z_C(\omega) = \frac{1}{j\omega C}$$

Inductor

$$Z_L(\omega) = j\omega L$$

Impedance is the proportionality factor relating the complex voltage across an element to the complex current through the element.

$$\tilde{i}(\omega) = \frac{\tilde{V}(\omega)}{Z(\omega)}$$

$$\tilde{V}(\omega) = \tilde{i}(\omega)Z(\omega)$$

Devices in Series and Parallel

$$Z_{\text{Series}} = Z_1 + Z_2$$

$$\frac{1}{Z_{\text{Parallel}}} = \frac{1}{Z_1} + \frac{1}{Z_2}$$

Impedance of ideal components in the Frequency Domain on Log-Log Plots

$$Z_C(\omega) = \frac{1}{j\omega C}$$

$$Z_R(\omega) = R$$

$$Z_L(\omega) = j\omega L$$

Complete set of plots:

- Log-log gain plot
- Log-Lin phase plot

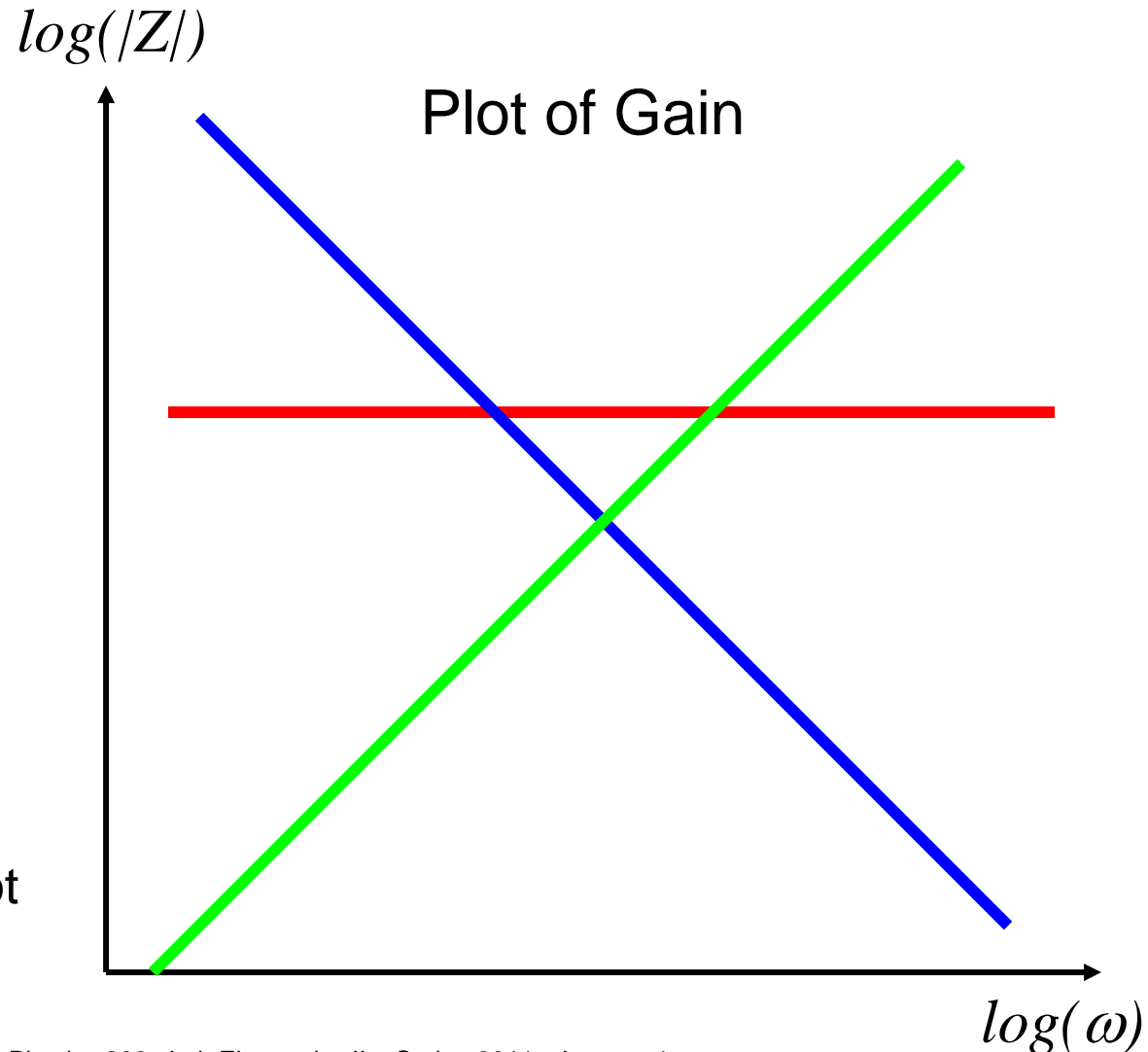

Simple Voltage Divider

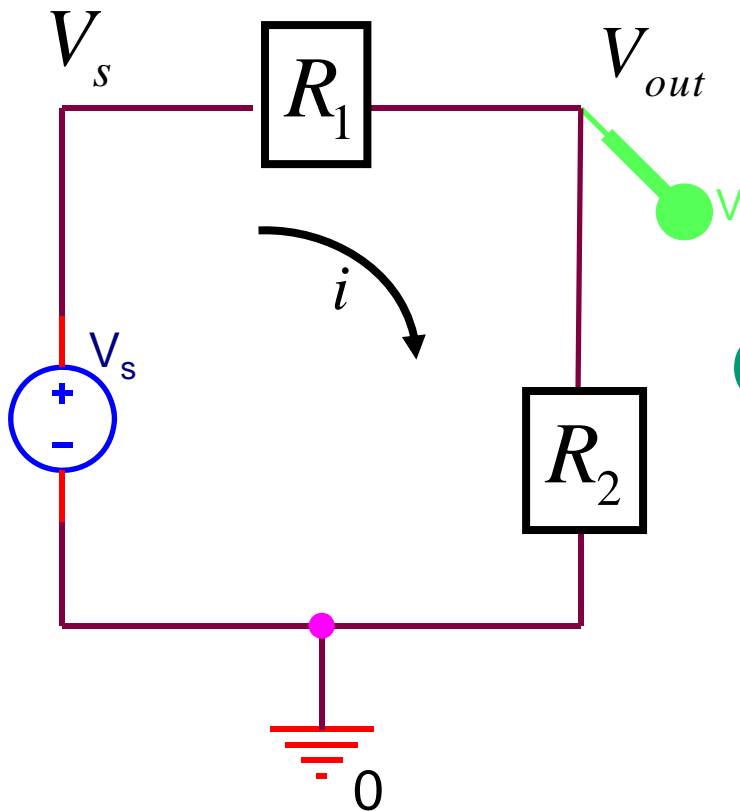

Current

$$i = \left(\frac{V_s}{R_1 + R_2} \right) = \left(\frac{V_s - V_{out}}{R_1} \right)$$

Output Voltage

$$V_{out} = \left(\frac{R_2}{R_1 + R_2} \right) V_s$$

Transfer Function

Gain (or attenuation)

$$G = \left| \frac{V_{out}}{V_s} \right| = \left(\frac{R_2}{R_1 + R_2} \right)$$

Passive Filter: Generalized Voltage Divider

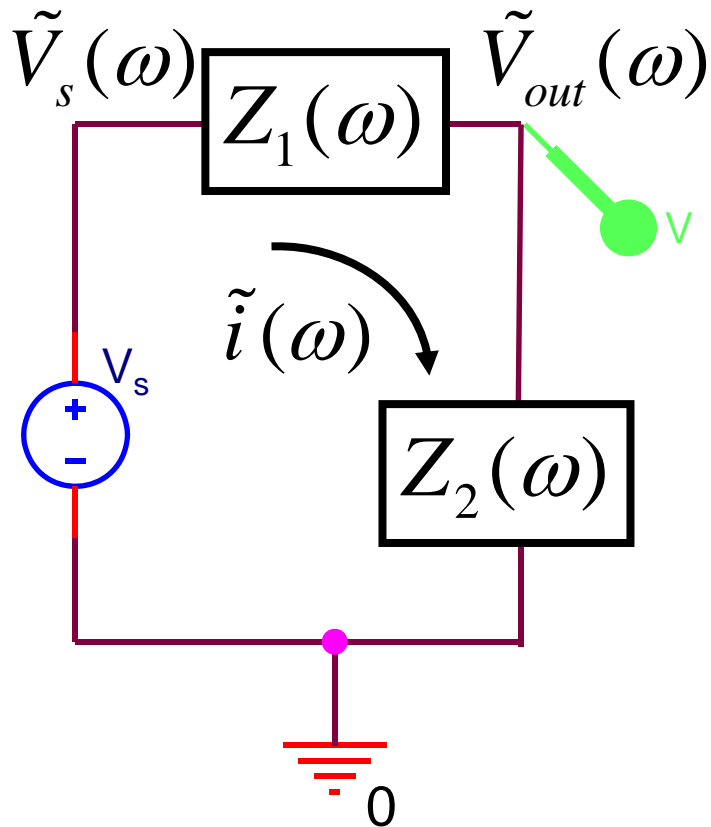

Current

$$\tilde{i}(\omega) = \left(\frac{\tilde{V}_s(\omega)}{Z_1(\omega) + Z_2(\omega)} \right) = \left(\frac{\tilde{V}_s(\omega) - \tilde{V}_{out}(\omega)}{Z_1(\omega)} \right)$$

Output Voltage

$$\tilde{V}_{out}(\omega) = \left(\frac{Z_2(\omega)}{Z_1(\omega) + Z_2(\omega)} \right) \tilde{V}_s(\omega)$$

Transfer Function $\tilde{T}(\omega)$
a.k.a $\tilde{T}(f)$ $f = \omega / (2\pi)$

Gain

$$\tilde{G}(\omega) = |\tilde{T}(\omega)| = \left| \frac{\tilde{V}_{out}(\omega)}{\tilde{V}_s(\omega)} \right| = \left(\frac{|Z_2(\omega)|}{|Z_1(\omega) + Z_2(\omega)|} \right)$$

Measuring an unknown $Z(\omega)$

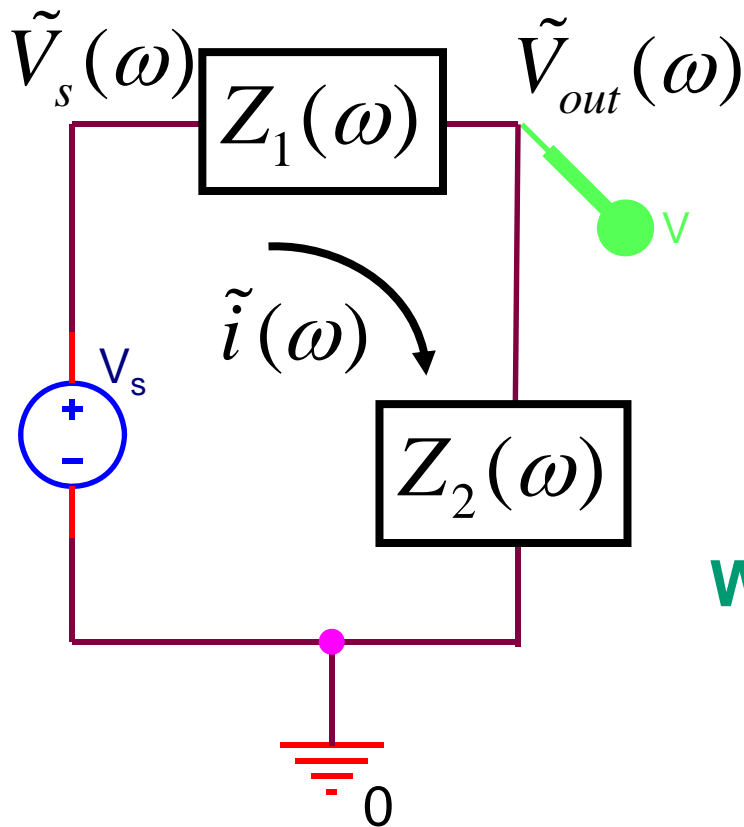

Can also write current as

$$\tilde{i}(\omega) = \left(\frac{\tilde{V}_{out}(\omega)}{Z_2(\omega)} \right) = \left(\frac{\tilde{V}_s(\omega) - \tilde{V}_{out}(\omega)}{Z_1(\omega)} \right)$$

Which can be rewritten as

$$Z_2(\omega) = \left(\frac{\tilde{V}_{out}(\omega) Z_1(\omega)}{\tilde{V}_s(\omega) - \tilde{V}_{out}(\omega)} \right)$$

If Z_1 is known,
by measuring source and output voltage,
complex impedance Z_2 can be determined.
=> Lab 1

Logarithmic Nomenclature

Decibel:

$$dB = 20 \log_{10} \left| \frac{V}{V_0} \right| = 10 \log_{10} \left| \frac{P}{P_0} \right|$$

Voltage Factor	Power Factor	Voltage Factor
1	1	0
$\sqrt{2}$ $1/\sqrt{2}$	2 $1/2$	3 -3
2 $1/2$	4 4	6 -6
10 $1/10$	100 $1/100$	20 -20
20 $1/20$	400 $1/400$	26 -26
100 $1/100$	10000 .0001	40 -40