

Today

1/25/11 Physics 262 Lecture 2

- **Filters**
 - **Basics: Analog versus Digital; Passive versus Active**
 - **Basic concepts and types of filters**
 - **Passband, Stopband, Cut-off, Slope, Knee, Decibels, and Bode plots**
- **Active Components and Filters**
 - **Review basics of OpAmps**
 - **First Order Active Filters**
 - **OpAmps with complex analysis**
 - **Transfer Functions**
 - **Bode Plot of Active Filters**
- **Homework**
 - **Reading 175-180 (up to 4.07) and 263-268 by 2/1/11**
 - **1.21 (p. 38), 1.22 (p. 39), 1.24(p.40, don't need phasors), and 1.26 (page 42) and problems on next slide**
- **Lab 2 this week**
 - **Lab 1 and Lab 2a notebooks due Friday 2/4/11 at 10am.**
 - **Work on lab 1a experiment (not PSpice) and Lab 2a meeting**
 - **Do Lab 2a pre-lab BEFORE lab meeting on Thursday 1/27/11**

Homework 2

- Passive RC Filter

- Write an expression for the complex transfer function ($V_{out}(f)/V_{in}(f)$) in terms of R, C, and f .
- Write an expression for the magnitude of the transfer function in terms of R and C. Draw a sketch of it with axis label with numbers for key values.
- Write an expression for the phase of the transfer function.
- What are values of the magnitude and phase of the transfer function at the cutoff frequency?
- Select a value for C so the cutoff frequency is 3.0kHz.

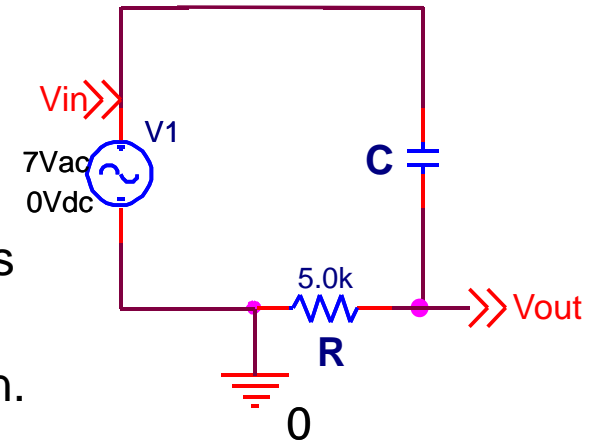

- Passive RL Filter

- Repeat but substitute an inductor L for the capacitor C
- Find value of L for a cutoff frequency of 1600 Hz.

- First-Order Active RC filter

- Repeat steps for RC Filter above, but for active filter circuit to the right. Write expressions in terms of C, R_1 , and R_2 .
- Select a value for C so the cutoff frequency is 6.0kHz.

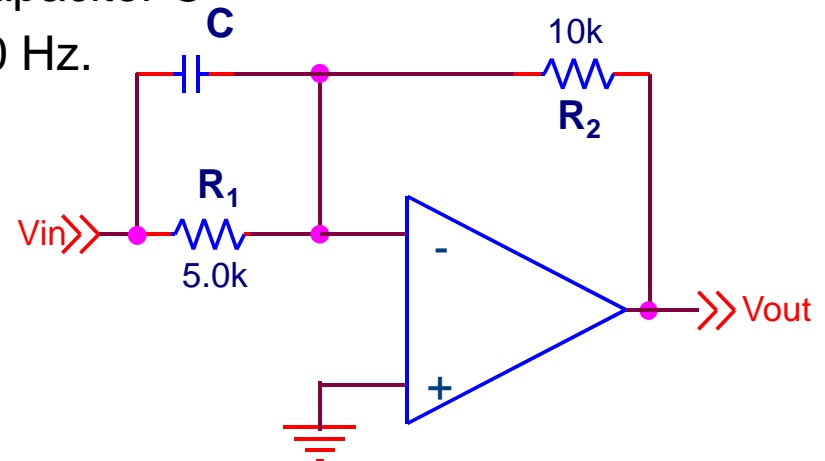

Filters

- Filters: An electrical filter is a device designed to pass a certain group of signals or suppress other groups of signals from a collection of signals.
- **Analog versus Digital Filters**
 - Analog Filters: Process real continuous, analog signals.
 - Digital Filters: Numerically process signals that have been discretely sampled and digitized.
- **Passive versus Active Analog Filters**
 - Passive Filters: Filters implemented with resistors, capacitors, and inductors. Gain is less than or equal to one.
 - Active Filters: Filters implemented with resistors, capacitors, inductors, and active devices such as operational amplifiers or transistors. Can have gain greater than one.

Basic Filter Concepts

- Frequency dependent impedances

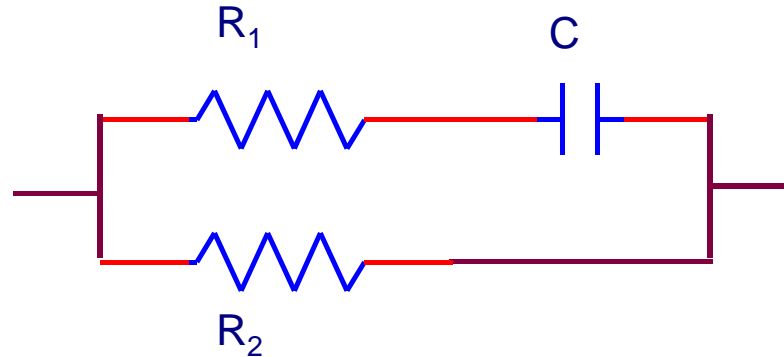

Low Frequencies:

C → infinity

circuit ⇒ R₂

High Frequencies:

C → 0

circuit ⇒ R₁ || R₂ (Z < R₂)

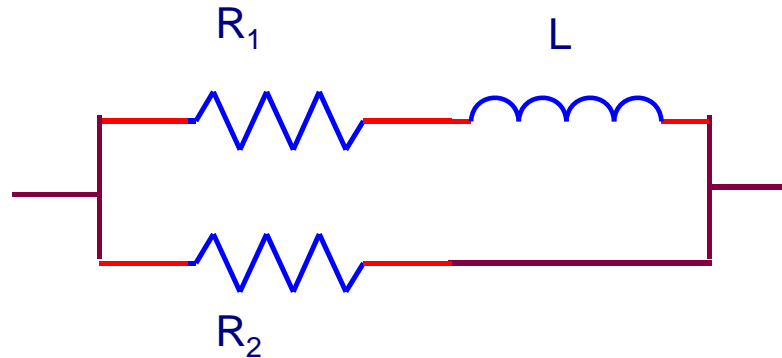

Low Frequencies:

L → 0

circuit ⇒ R₁ || R₂ (Z < R₂)

High Frequencies:

L → infinity

circuit ⇒ R₂

Types of Ideal Filters

- Transfer Functions of Ideal Filters

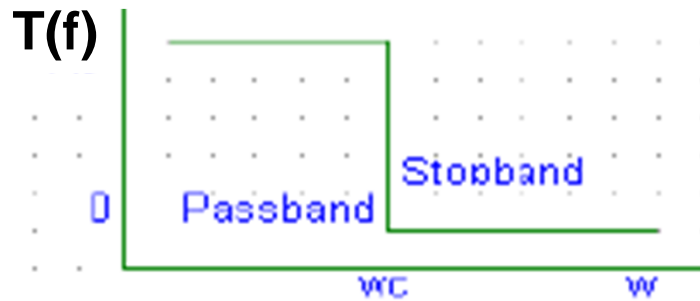

Ideal Low-Pass Filter

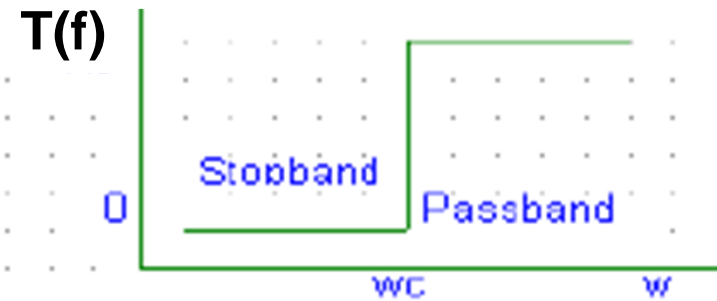

Ideal High-Pass Filter

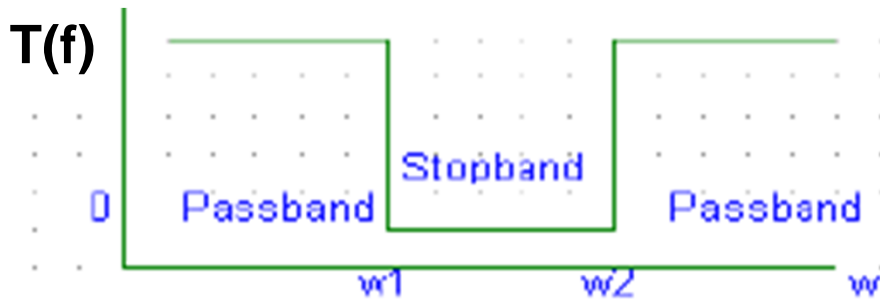

Ideal Band-Reject Filter

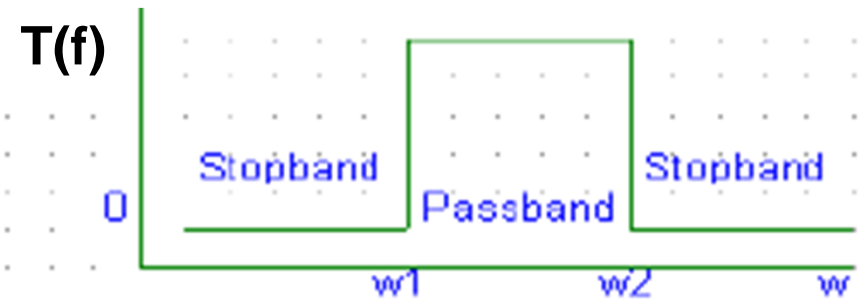

Ideal Band-Pass Filter

Passband(s): Frequency that pass weakly attenuated or have gain.

Stopband(s): Frequencies that are “strongly” attenuated.

Real World Filters: No sharp cutoffs; gain rolls off, stopband $G > 0$.

Passive Filter: Generalized Voltage Divider

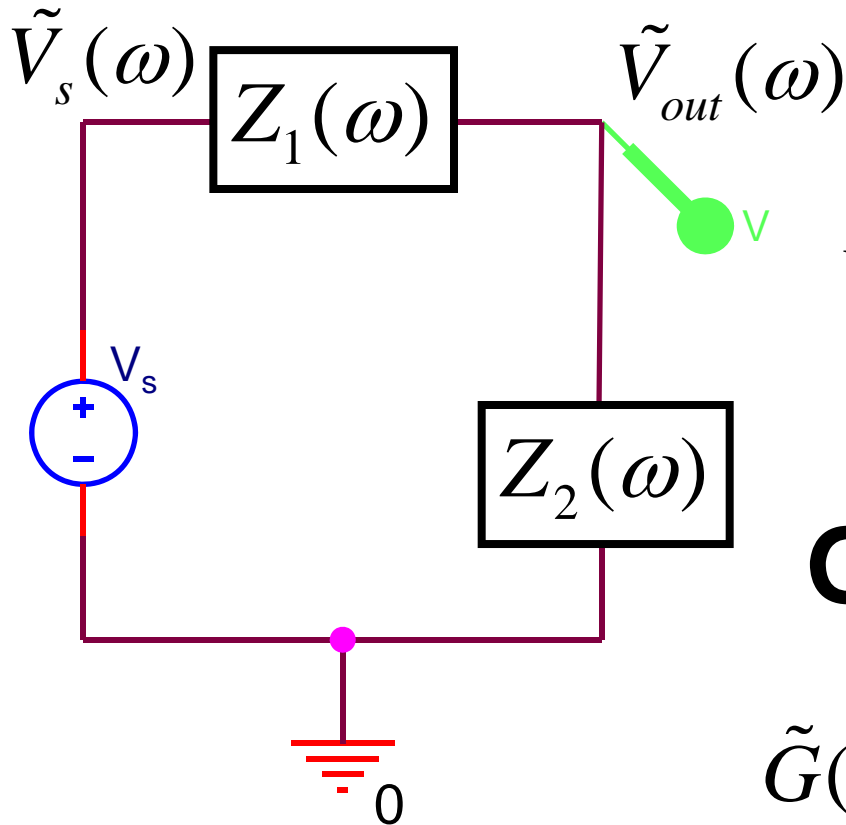

$$\tilde{V}_{out}(\omega) = \left(\frac{Z_2(\omega)}{Z_1(\omega) + Z_2(\omega)} \right) \tilde{V}_s(\omega)$$

Gain (or attenuation)

$$\tilde{G}(\omega) = \frac{\tilde{V}_{out}(\omega)}{\tilde{V}_s(\omega)} = \left(\frac{Z_2(\omega)}{Z_1(\omega) + Z_2(\omega)} \right)$$

Transfer Function $\tilde{T}(f) = \left(\frac{Z_2(f)}{Z_1(f) + Z_2(f)} \right) \quad f = \omega / (2\pi)$

Passive RC Filter Analysis

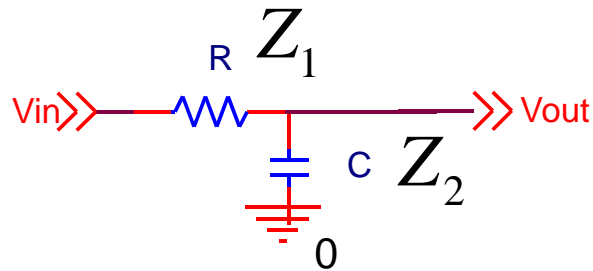

$$\omega = 2\pi f$$

$$\begin{aligned} \tilde{T}(f) &= \left(\frac{(1/(j\omega C))}{R + (1/(j\omega C))} \right) = \left(\frac{1}{j\omega RC + 1} \right) \\ &= \left(\frac{1}{\sqrt{(\omega RC)^2 + 1}} \right) \exp \left(-j \tan^{-1} \left(\frac{\omega RC}{1} \right) \right) \\ &= |\tilde{T}(f)| \exp(j\phi(f)) \end{aligned}$$

$$\text{Mag} =$$

$$|\tilde{T}(f)| = \left(\frac{1}{\sqrt{1 + (f/f_c)^2}} \right)$$

$$\text{Phase} =$$

$$\phi(f) = -\tan^{-1}(f/f_c)$$

Cut-off frequency

$$f_c = \frac{1}{2\pi RC}$$

Filter Gain Characterization

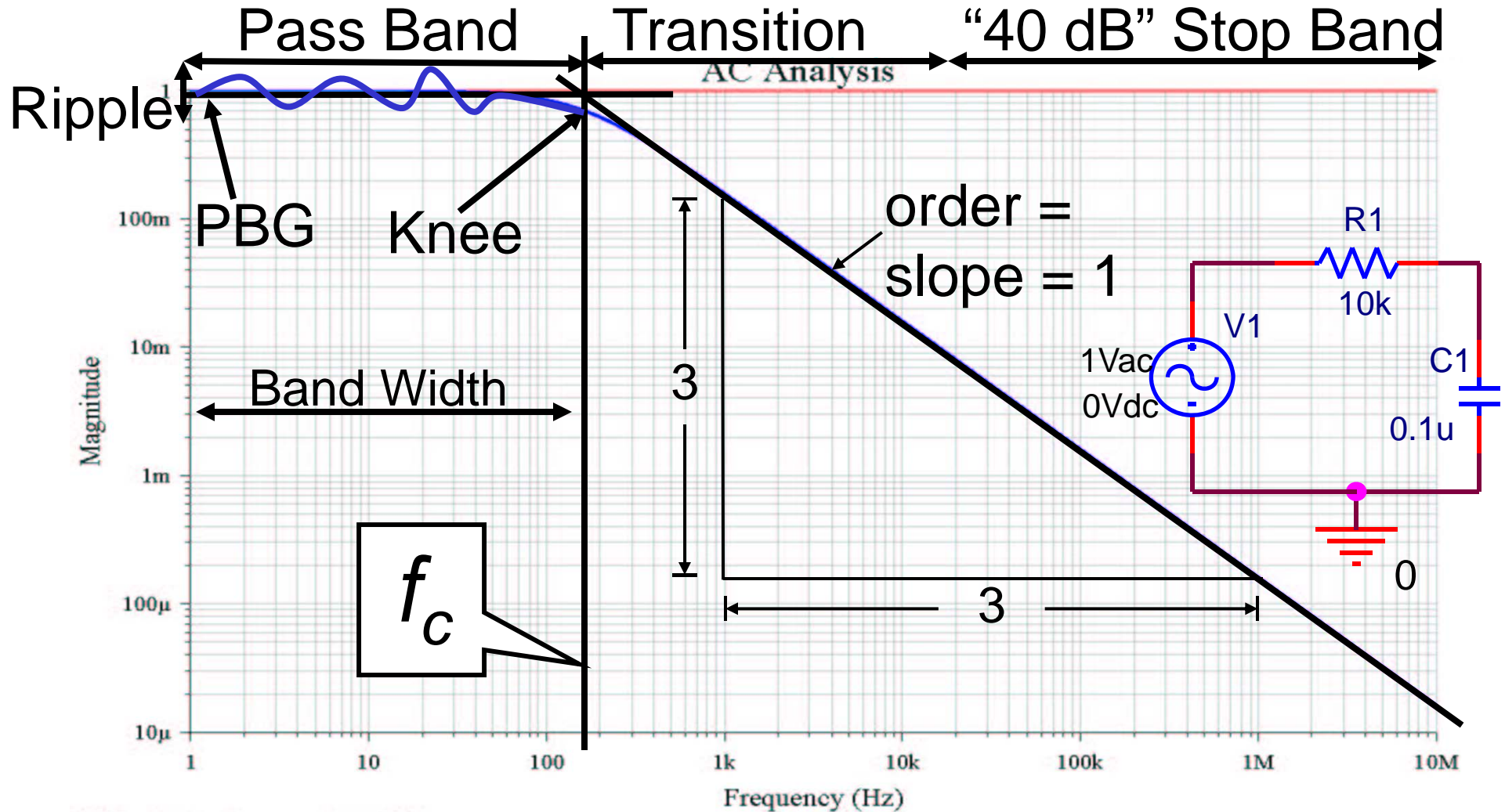

Gain-Frequency plot (log-log) of the Bode Diagram

Logarithmic Nomenclature

Define *Decibel*:

$$dB = 20 \log_{10} \left| \frac{V}{V_0} \right| = 10 \log_{10} \left| \frac{P}{P_0} \right|$$

Factor		dB	
1		0	
$\sqrt{2}$	$1/\sqrt{2}$	3	-3
2	$1/2$	6	-6
10	$1/10$	20	-20
30	$1/30$	30	-30
100	$1/100$	40	-40

Multipliers on
a Log Axis

Name	Ratio
Octave	2:1
Decade	10:1

Bode Diagrams

Bode gain diagram:

- Log-Log plot of $|T(f)|$ vs f
- $\text{Log}(f) = \text{x-axis}$
- $\text{Log}(|T(f)|) = \text{y-axis}$

Bode phase diagram:

- Log-Lin Plots of $\text{Phase}(f)$ vs f
- $\text{Log}(f) = \text{x-axis}$
- $\text{Phase}(f) = \text{y-axis (Linear)}$

Quick analysis of filter behavior:

- Filter type
- Pass band gain
- Cut-off frequency, aka;
 - Corner or Knee frequency
 - 3dB down point ($|T(f)| = 1/\sqrt{2}$)
- Stop band (“skirt”) slope (order)
- Phase shift

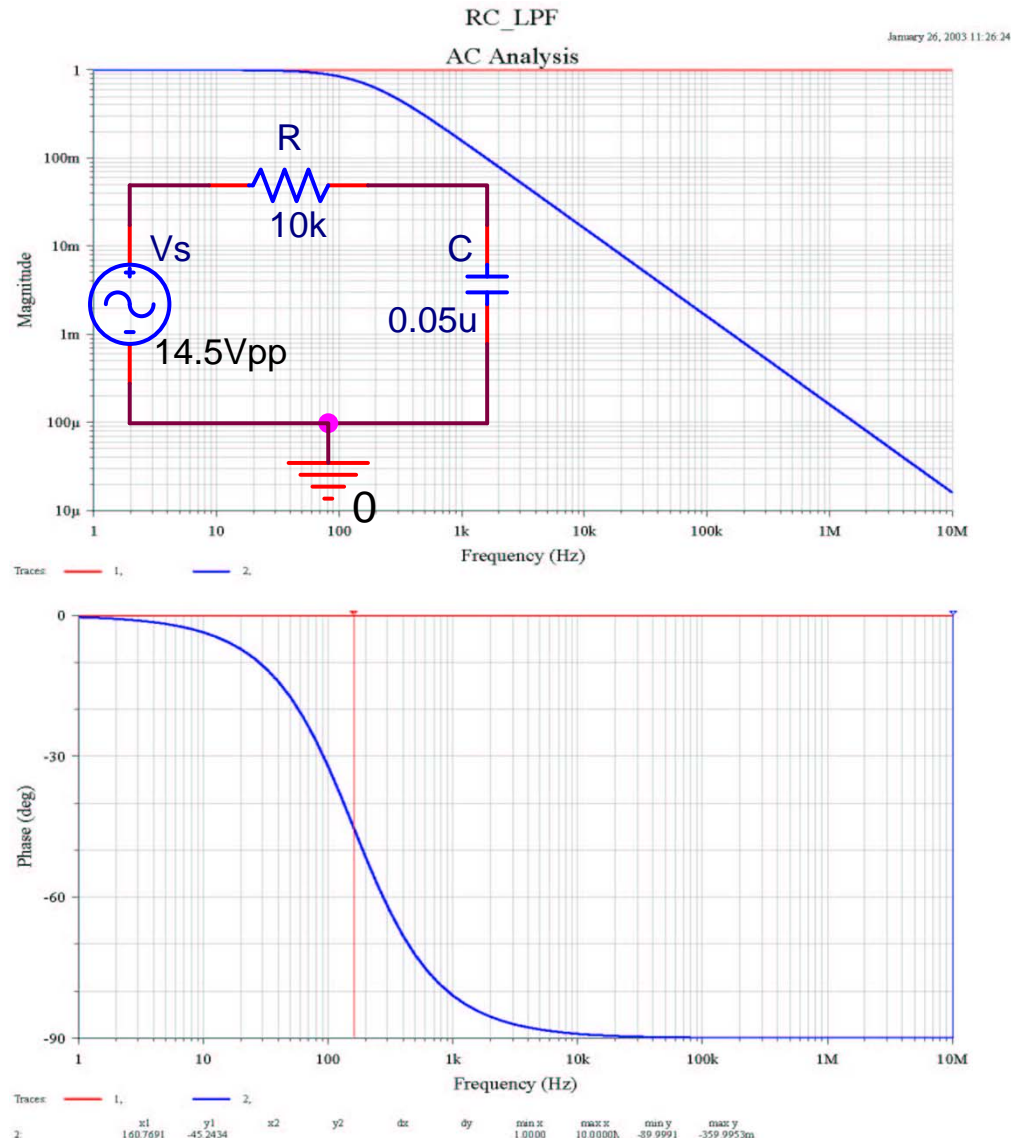

Bode Diagram: Phase

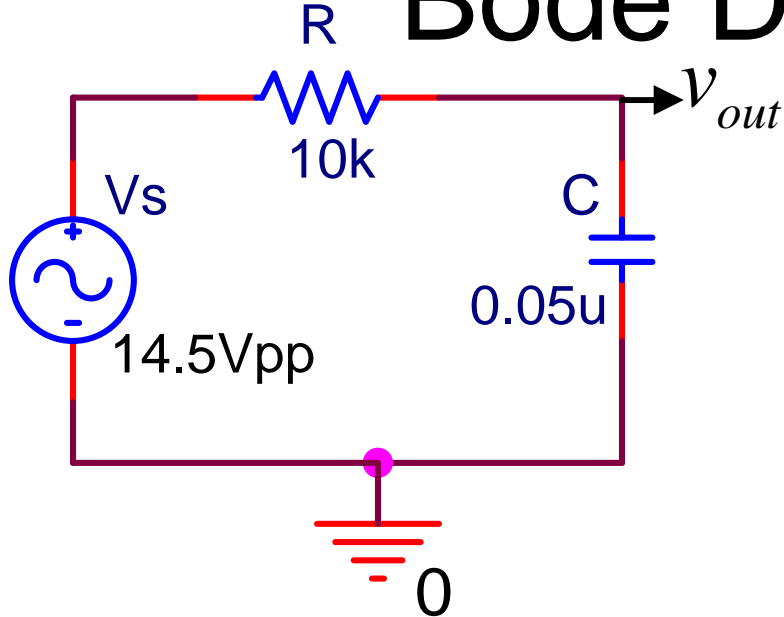

$$\text{As } \omega \rightarrow 0, \quad Z_C \rightarrow \infty$$

$$\phi_{v_{out}} = \phi_{v_S} \text{ (in phase)}$$

$$\text{As } \omega \rightarrow \infty, \quad Z_C \rightarrow 0$$

$$\text{Since } v_R = i_R R = v_S,$$

$i_C = i_R$ and is in phase with v_S

But, v_C is -90° out of phase with i_C

So, v_{out} is -90° out of phase with v_S .

Multiple-Order (Passive) Filter

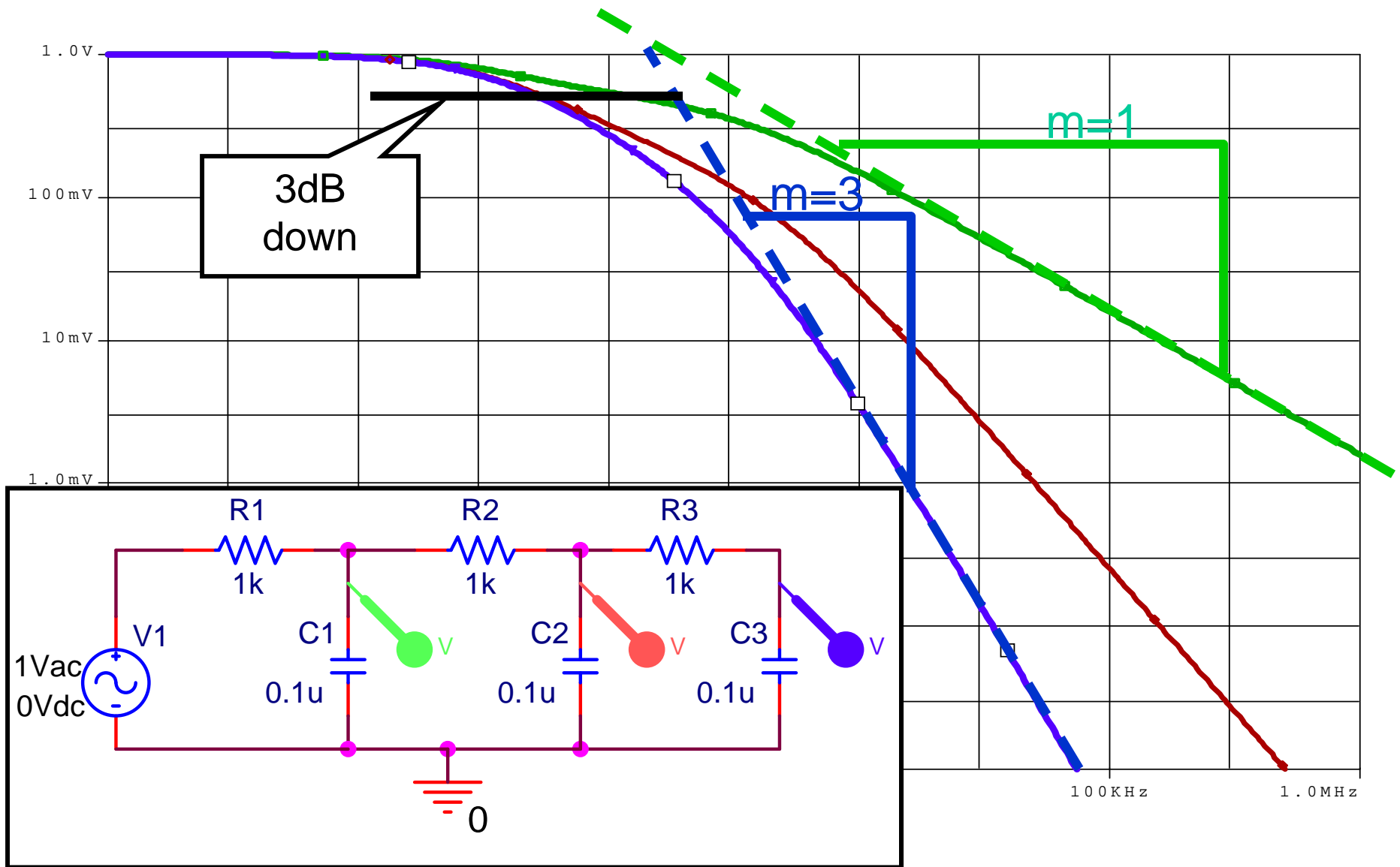

Cascaded Passive Filters

Cascaded passive filters increase the order of the total filter.

Order = number of cascaded first order filters

- *Slope in stopband = order of filter*

Each section's input impedance will load previous section.

- *Degrades response and load capacity*

No gain, only loss

- *Gain (voltage or current) has to included separately*

Could introduce buffers (op-amps) as integral part of filter.

Passive and Active Filters

Passive Filter

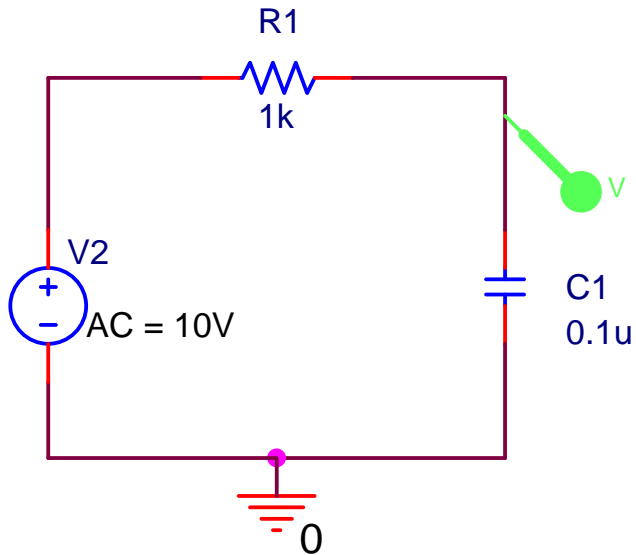

Equivalent OpAmp Filter/ First order Active Filter

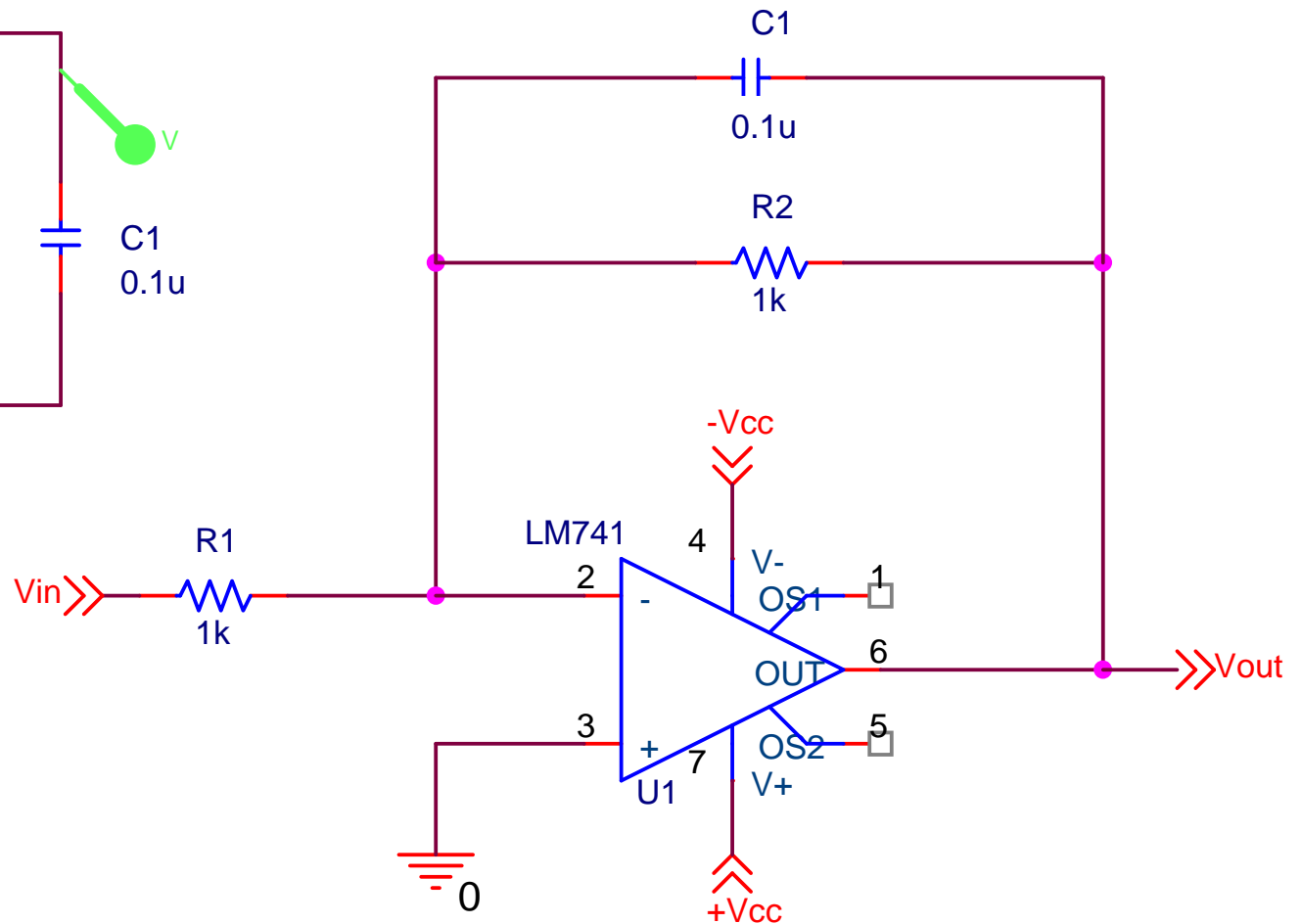

Operational Amplifiers Review

OpAmps Basics

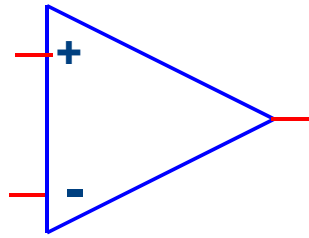

Open Loop: $v_{out} = A(v_p - v_n)$

Closed Loop: $v_n = v_p$ $i_n = 0$, $i_p = 0$

OpAmps in common feedback circuits

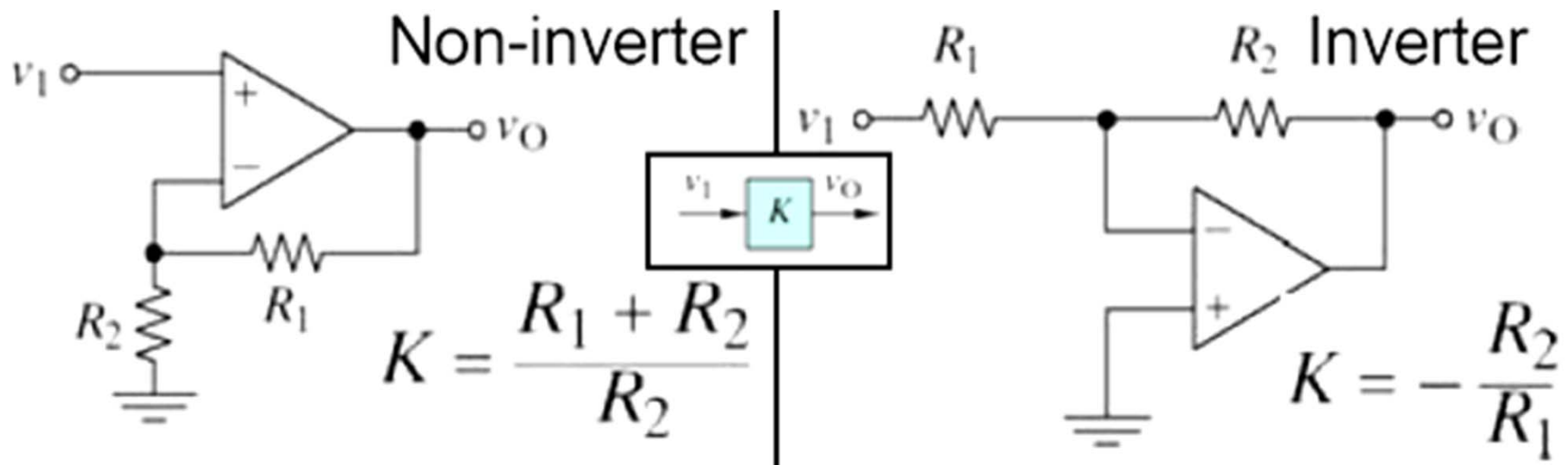

First Order Active Filter Analysis

$$\tilde{V}_- = 0$$

$$\tilde{i}_1 = \frac{\tilde{V}_{in}}{Z_1}$$

$$\tilde{i}_- = 0, \text{ so}$$

$$\tilde{i}_2 = \tilde{i}_1 = \frac{-\tilde{V}_{out}}{Z_2}$$

$$\tilde{V}_{out}(f) = -\frac{Z_2(f)\tilde{V}_{in}(f)}{Z_1(f)}$$

$$\tilde{T}(f) = \frac{-Z_2(f)}{Z_1(f)}$$

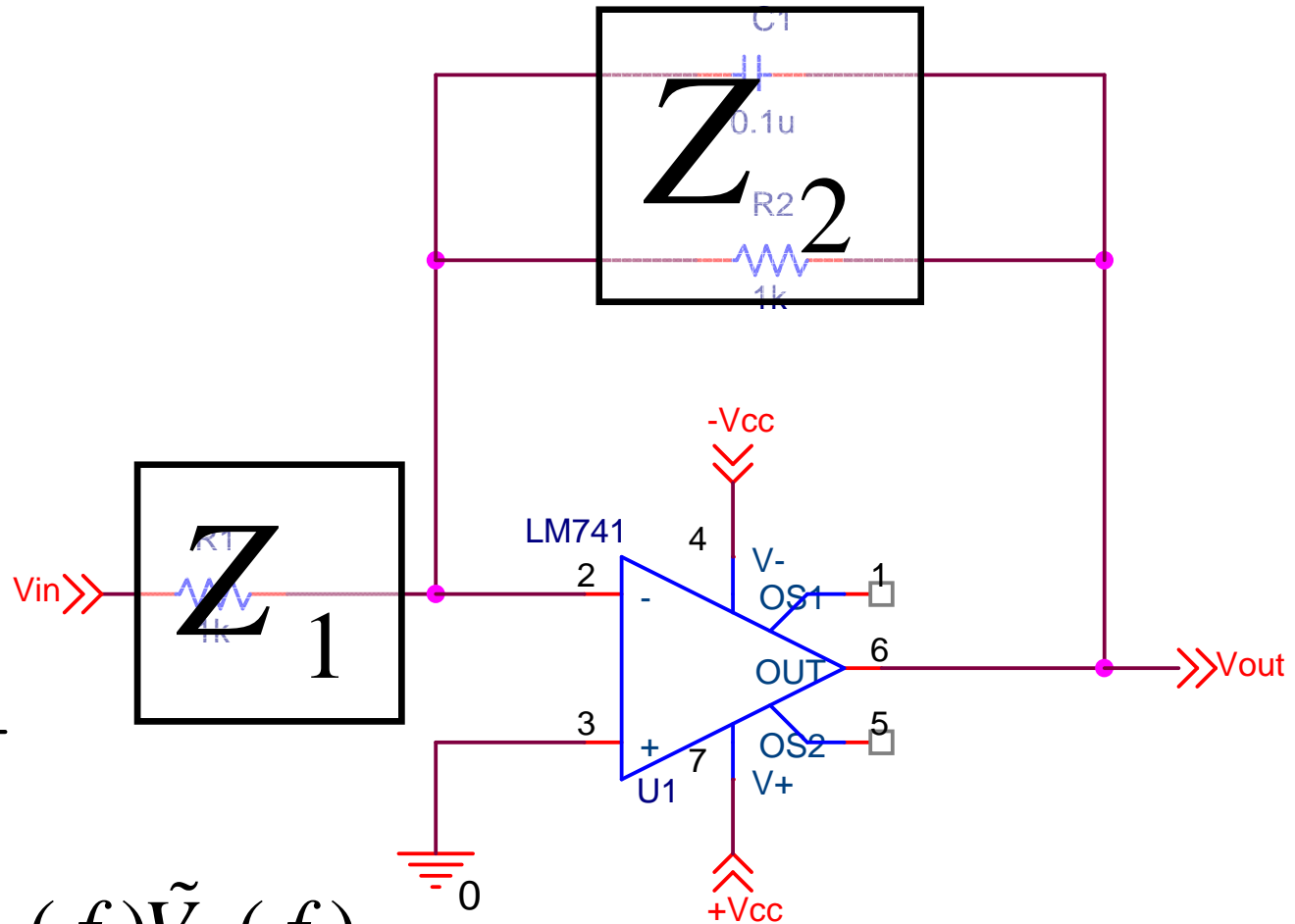

First Order Active Filter Analysis

$$Z_2 = \frac{1}{\frac{1}{jC\omega} + \frac{1}{R_2}} = \frac{1}{jC\omega + \frac{1}{R_2}} = \frac{R_2}{jCR_2\omega + 1}$$

$$\tilde{T}(f) = \frac{\tilde{V}_{out}(f)}{\tilde{V}_{in}(f)} = \frac{-Z_2}{Z_1} = \frac{\frac{-R_2}{jR_2C\omega + 1}}{R_1} = \left(\frac{R_2}{R_1}\right) \frac{-1}{j(\omega/\omega_c) + 1}$$

$$\omega_c = \frac{1}{R_2C}$$

First Order Active Filter Analysis - II

$$\tilde{T}(f) = \frac{\tilde{V}_{out}(f)}{\tilde{V}_{in}(f)} = \left(\frac{R_2}{R_1} \right) \frac{-1}{1 + j\omega / \omega_c} = \left| \frac{\tilde{V}_{out}}{\tilde{V}_{in}} \right| \exp(j\varphi(f))$$

$$|\tilde{T}(f)| = \left(\frac{R_2}{R_1} \right) \frac{1}{\sqrt{1 + (f / f_c)^2}} \quad f_c = \frac{1}{2\pi R_2 C}$$

$$\varphi(f) = 180^\circ - \tan^{-1}(f / f_c)$$

Gain-Frequency for First Order Active Filter

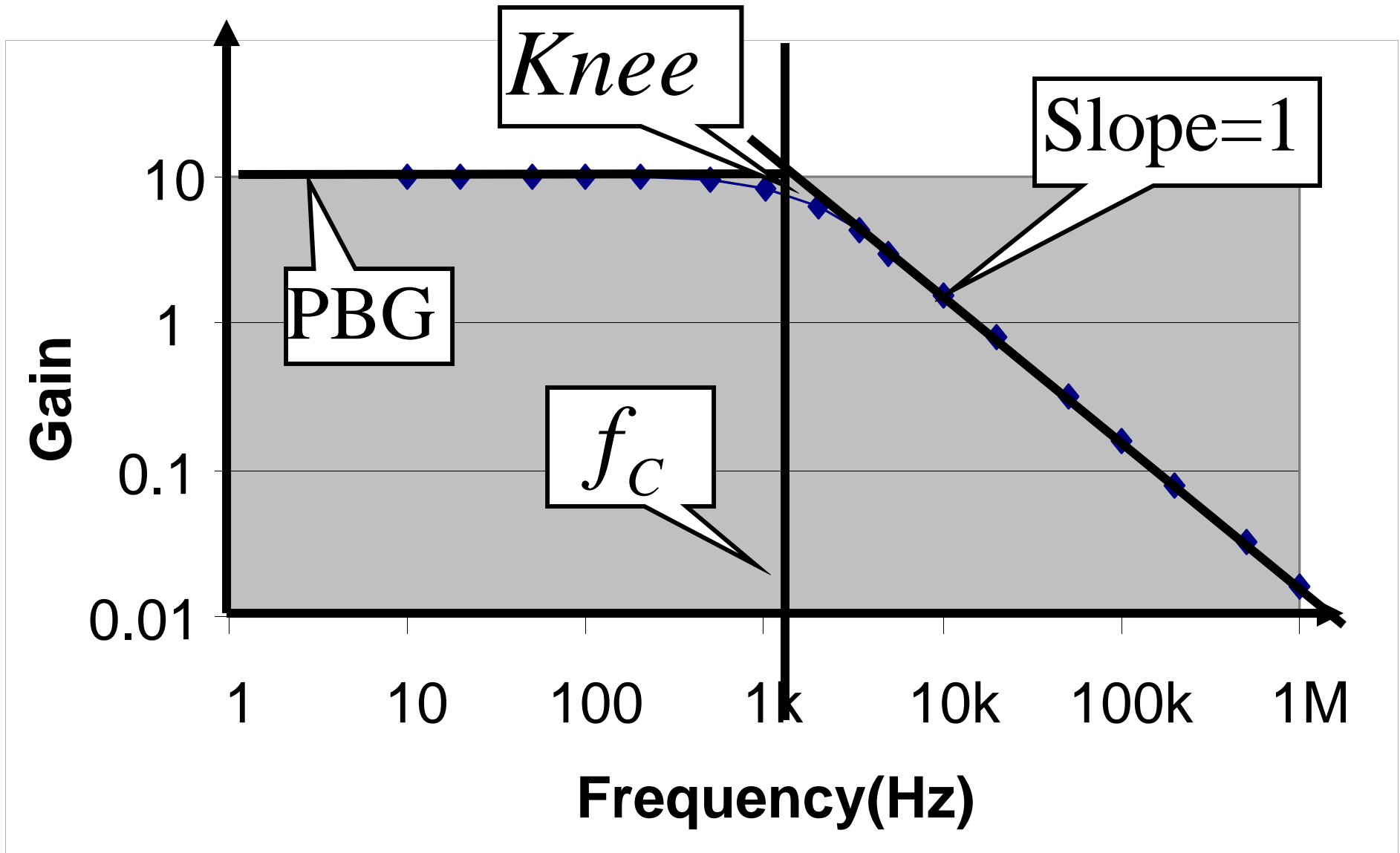

PBG = Gain Pass Band

Impedance Converters

Optional “for fun” slides

Active Circuits can be used to

- Invert Impedance
 - An applied voltage must sink current
- Convert “capacitor” into an “inductor”
 - Make hard to manufacture inductors out of cheap capacitors

Negative-Impedance Converter

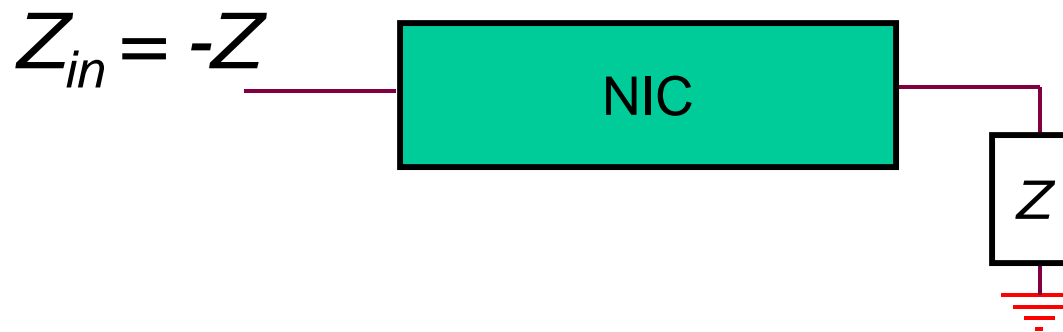
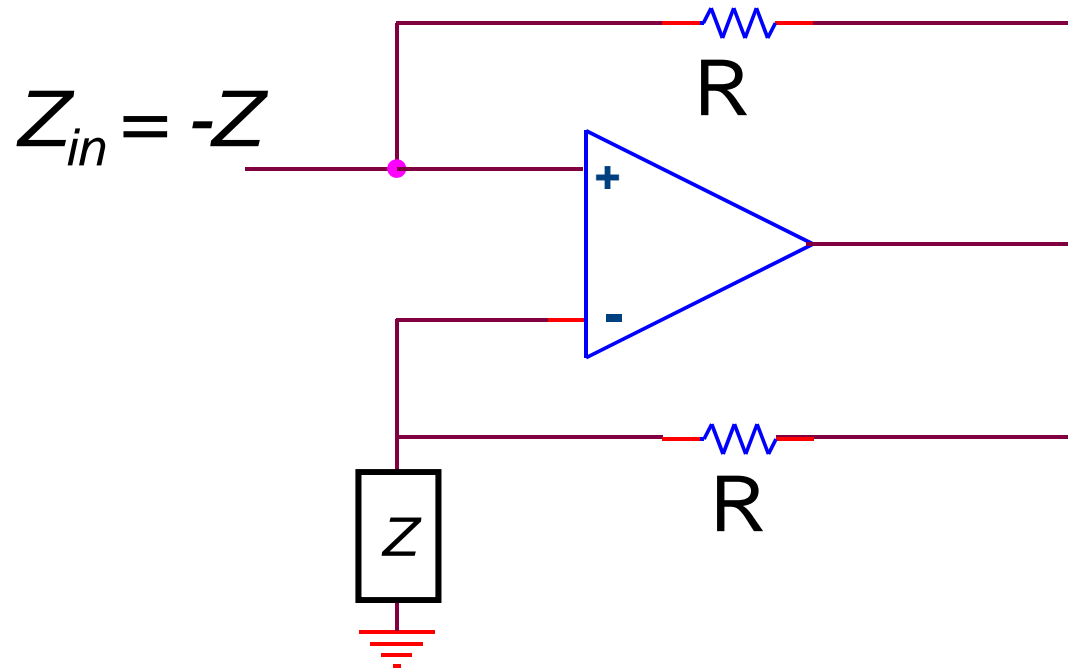

Gyrator

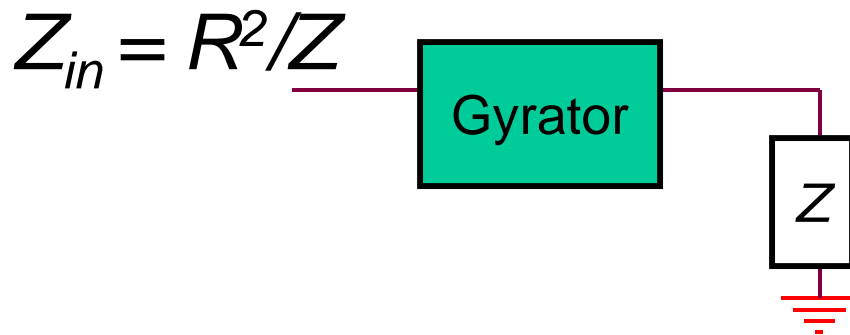
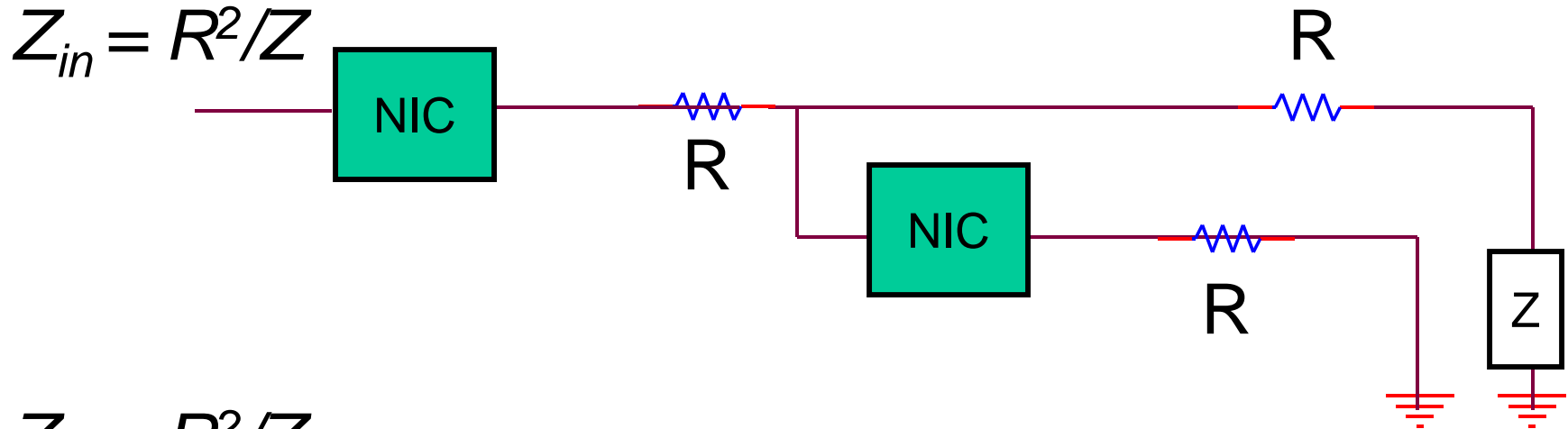

If $Z = 1/(j\omega C)$,

Then $Z_{in} = j\omega CR^2$

A capacitor (plus op amps) can act as an inductor

$$L = CR^2$$