

Today

2/8/11 Lecture 4

- **Higher Order Active Filters**
 - **Butterworth Active Filters**
 - Design
 - Performance
 - **Other Higher Order Filters**
 - Butterworth, Bessel, Chebyshev
 - Advantages and Disadvantages
 - Frequency and Temporal Characteristics
- **Homework**
 - See next slide
- **Reading**
 - H&H Ed 2 268-276
- **Lab this week**
 - Lab 3
 - Do pre-lab of Lab 3 BEFORE lab on Thursday, TA check at start
 - Lab 2b due this Friday at 10am
- **Quiz**

Homework

Due 2/15/11 HW4

1. Design a 2- pole Butterworth low pass filter with cut-off frequency $\sim 60\text{kHz}$. What is the formula for its gain as a function of frequency? What is its attenuation (in dB) at $f=3f_c$?
2. Design a 4- pole Butterworth high pass filter with cut-off frequency $\sim 30\text{kHz}$. What is the formula for its gain as a function of frequency? What is its attenuation (in dB) at $f=f_c/2$?
3. Design a 4- pole Bessel low pass filter with cut-off frequency $\sim 30\text{kHz}$.

Design of 2nd Order Active Filters

All the 2nd order active filter circuits have the same basic design

– Frequency selective RC circuit can be

- Band-pass (see H&H Figure 5.16)
- Low-pass

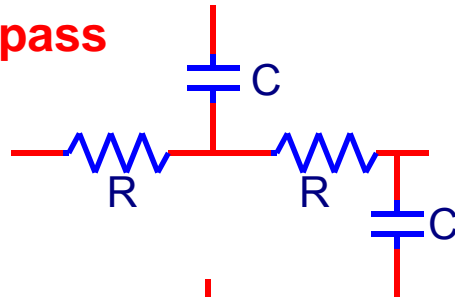

- High-pass

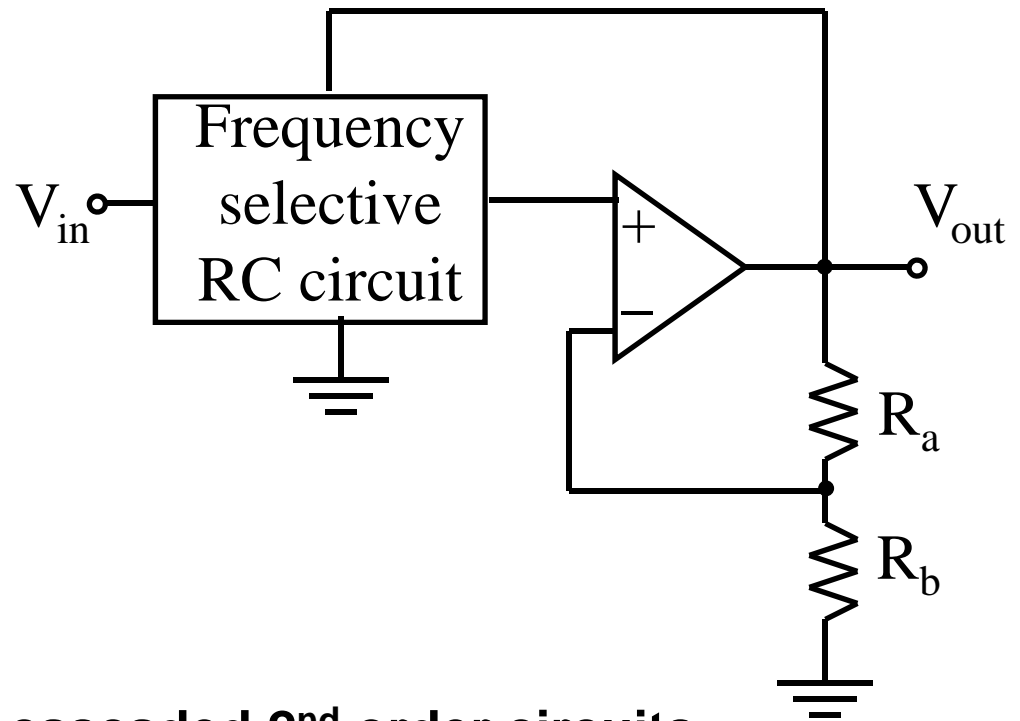
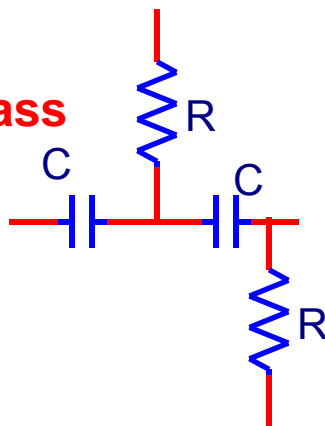

Higher order (>2) active filters are cascaded 2nd order circuits

- Built up by cascading basic filter circuits: $V_{out_previous} \Rightarrow V_{in_next}$
- Only one VCVS and one op-amp is needed per every two orders

2nd Order Butterworth Design

1-stage (2-pole) filter design:

	Butterworth	Bessel
Poles	K	f_n K
2	1.59	1.27 1.27

Start with desire f_c

Butterworth: $RC=1/(2\pi f_c)$ and $R_a=(K-1)R_b$

Typically $R_b=R$ in RC
R is typically 10-100K ohm.
(not hard rule)

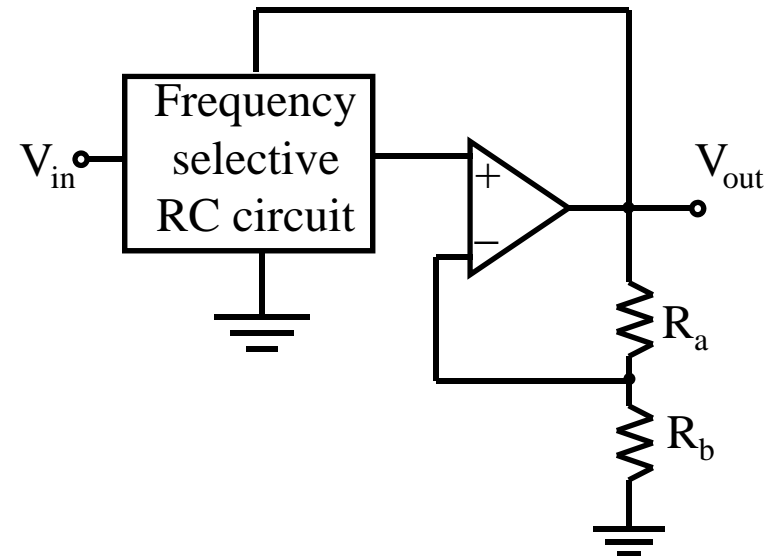

Higher Order Butterworth LPF Design

VCVS Low-Pass Filter Design is the same for all stages: $RC=1/(2\pi f_c)$

f_c is desired 3dB frequency
of total n-pole filter

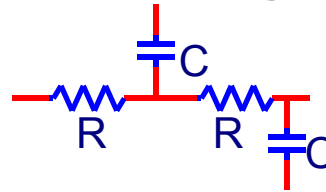

4th Other Active Filter

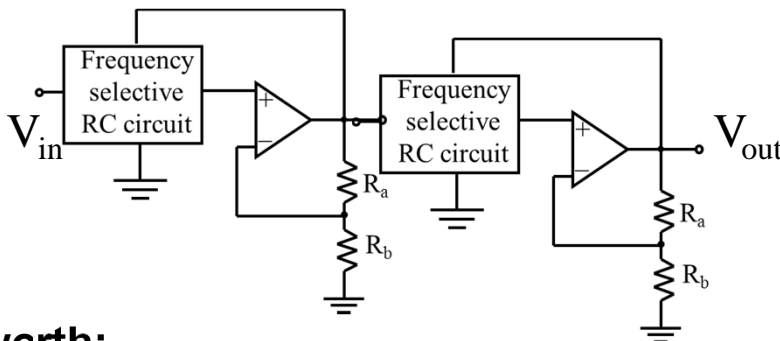

Poles	Stage(n)	Butterworth K_n
2	1	1.59
4	1	1.15
	2	2.24
6	1	1.07
	2	1.59
	3	2.48

Butterworth:

RC circuit is the same for all stages (Determined by desired f_c)

Only the gain changes for each stage

$$R_a = (K_n - 1)R_b$$

Typically gains increase down the line to avoid dynamic range issues

Total Gain of multi-stage filter = product of the K_n 's

For high pass filter: Same design table except:

Use high pass VCVS

Use $1/f_n$ to determine RC

4th Order Butterworth

2-stage (4-pole) Filter designs:

Butterworth		
Poles	Stage(n)	K_n
4	1	1.15
	2	2.24

Butterworth:

$$R_1 C_1 = R_2 C_2 = 1/(2\pi f_c)$$

$$R_{a1} = (K_1 - 1)R_{b1} = (1.15 - 1)R_{b1}$$

$$R_{a2} = (K_2 - 1)R_{b2} = (2.24 - 1)R_{b2}$$

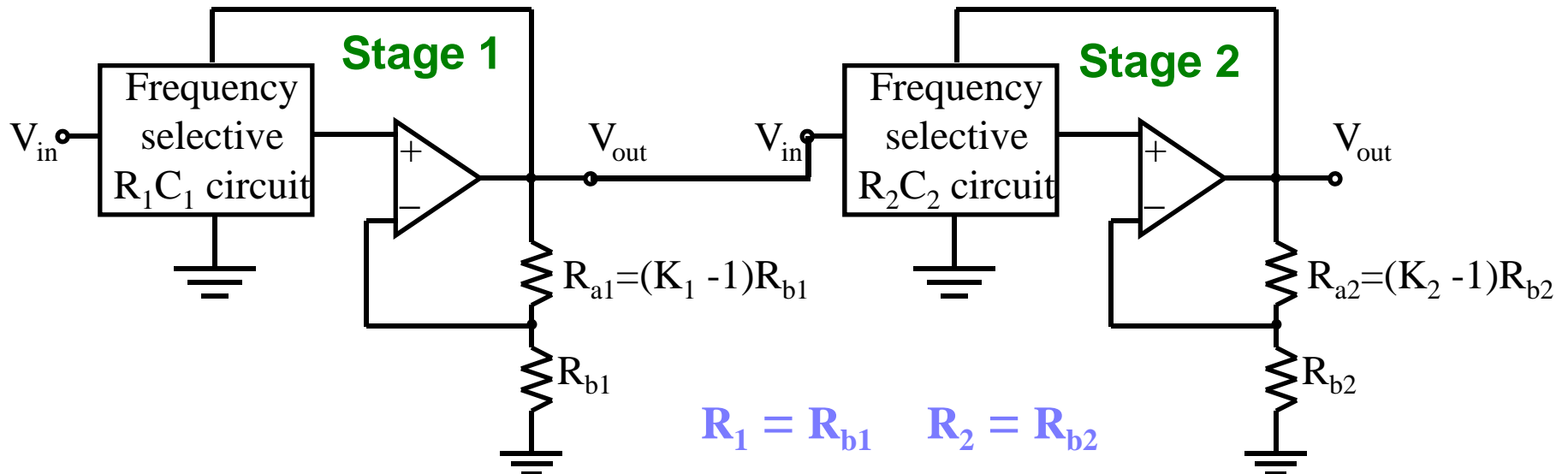

Butterworth Response

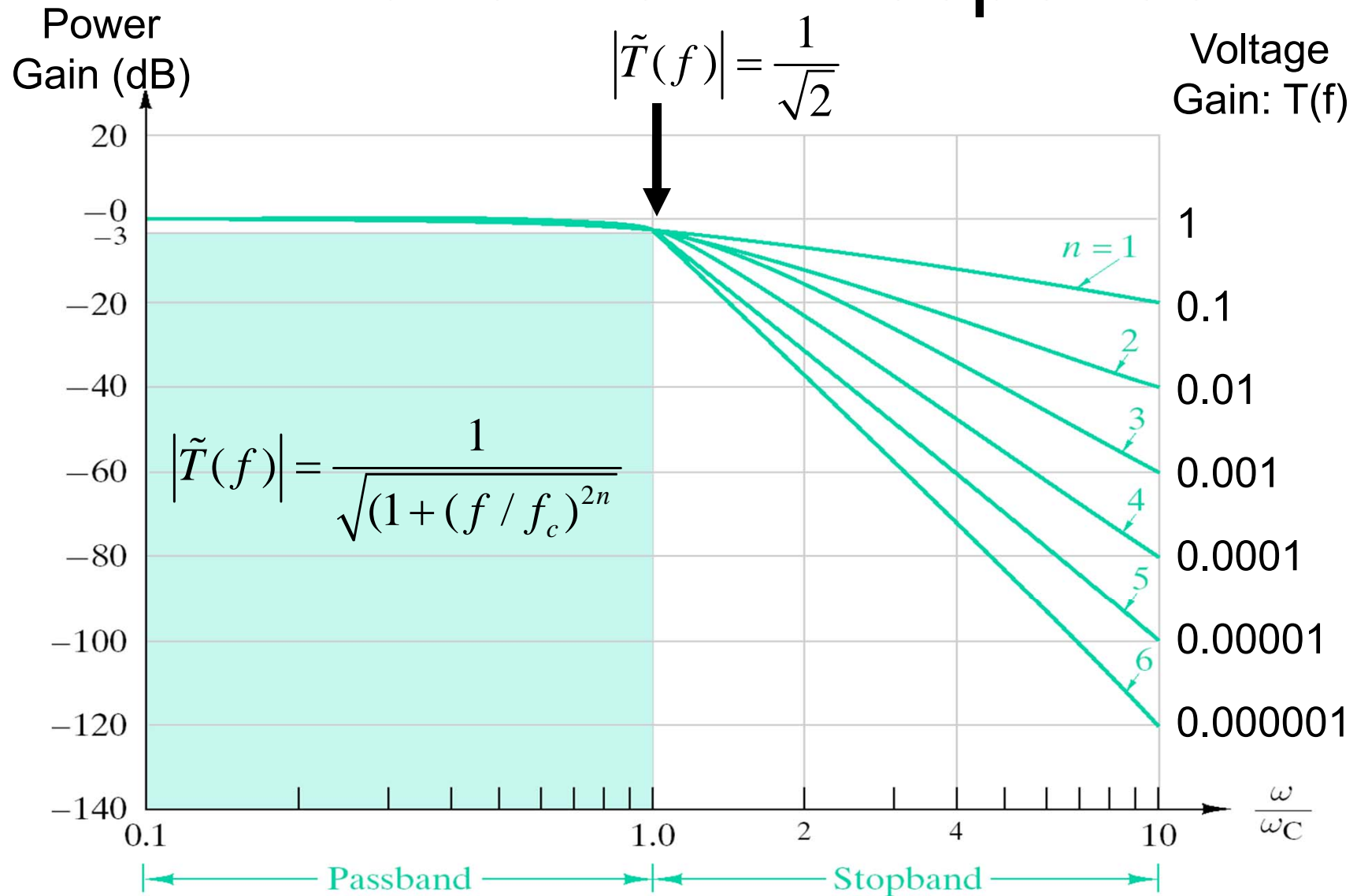

Butterworth High Pass Filter Response

Same design table except:

Use high pass VCVS

Use $1/f_n$ to determine RC

$$|\tilde{T}(f)| = \frac{1}{\sqrt{2}}$$

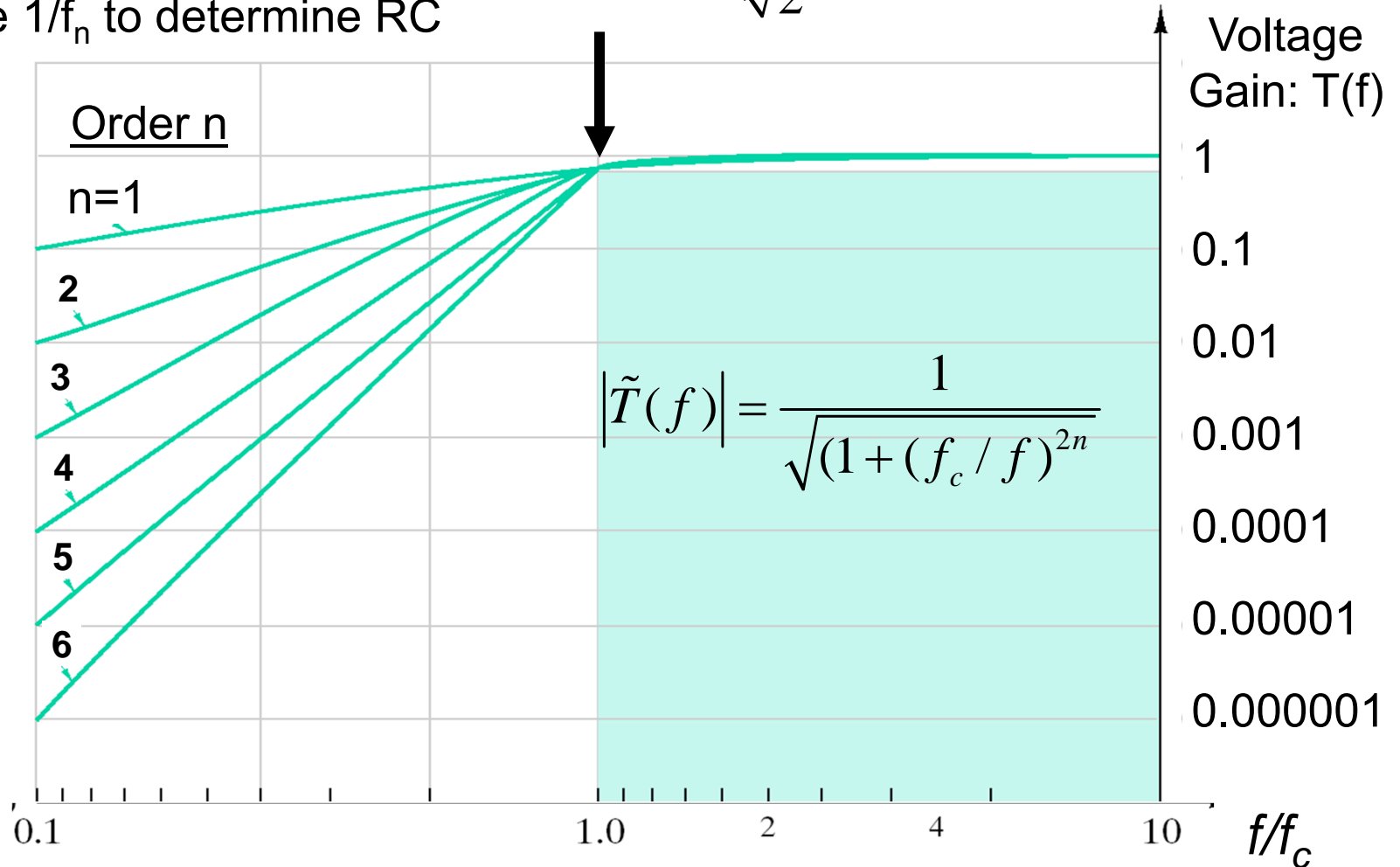

Temporal step response of Butterworth filters (orders = 2, 3, 4, 5 and 10)

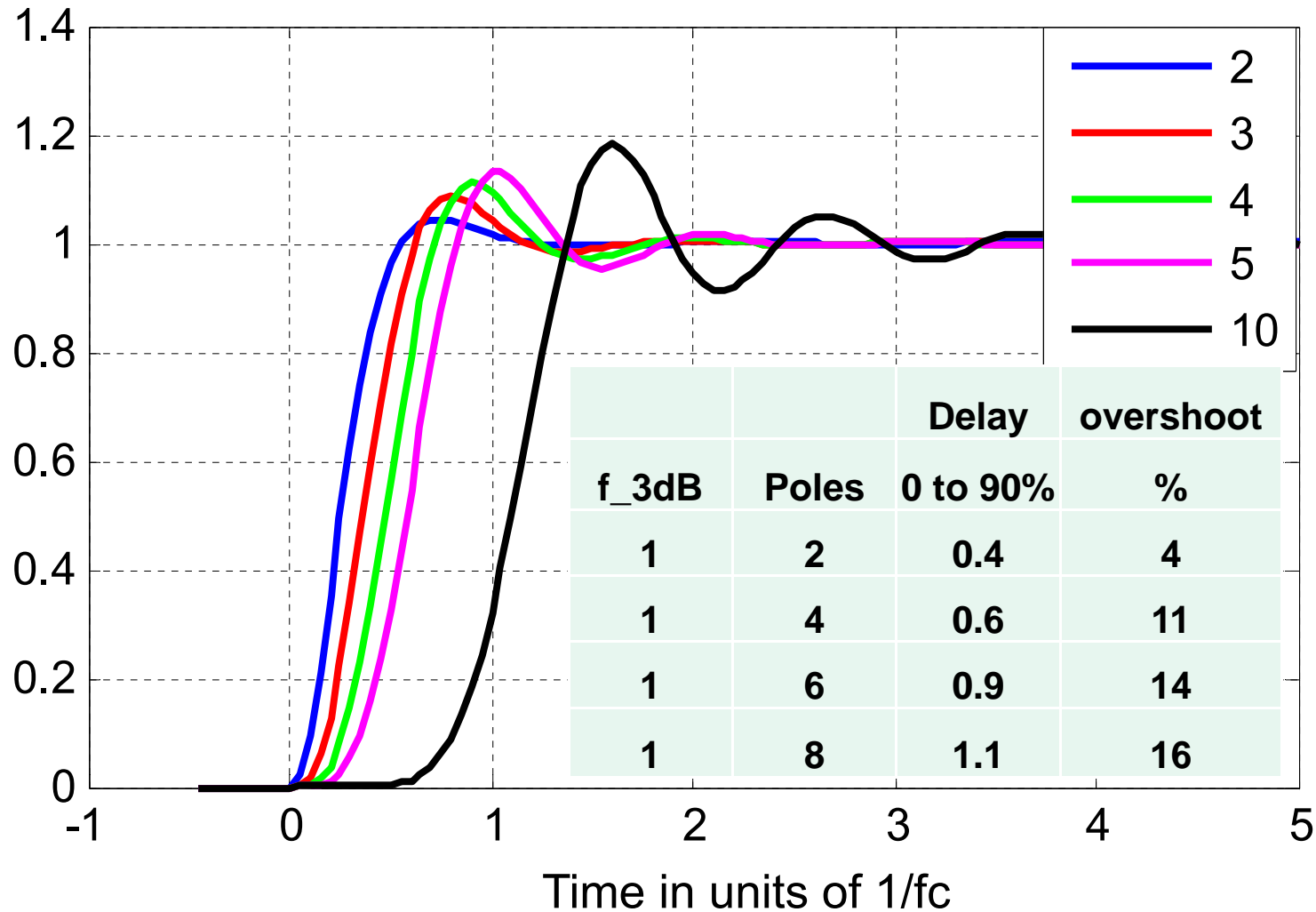

Review Butterworth Design

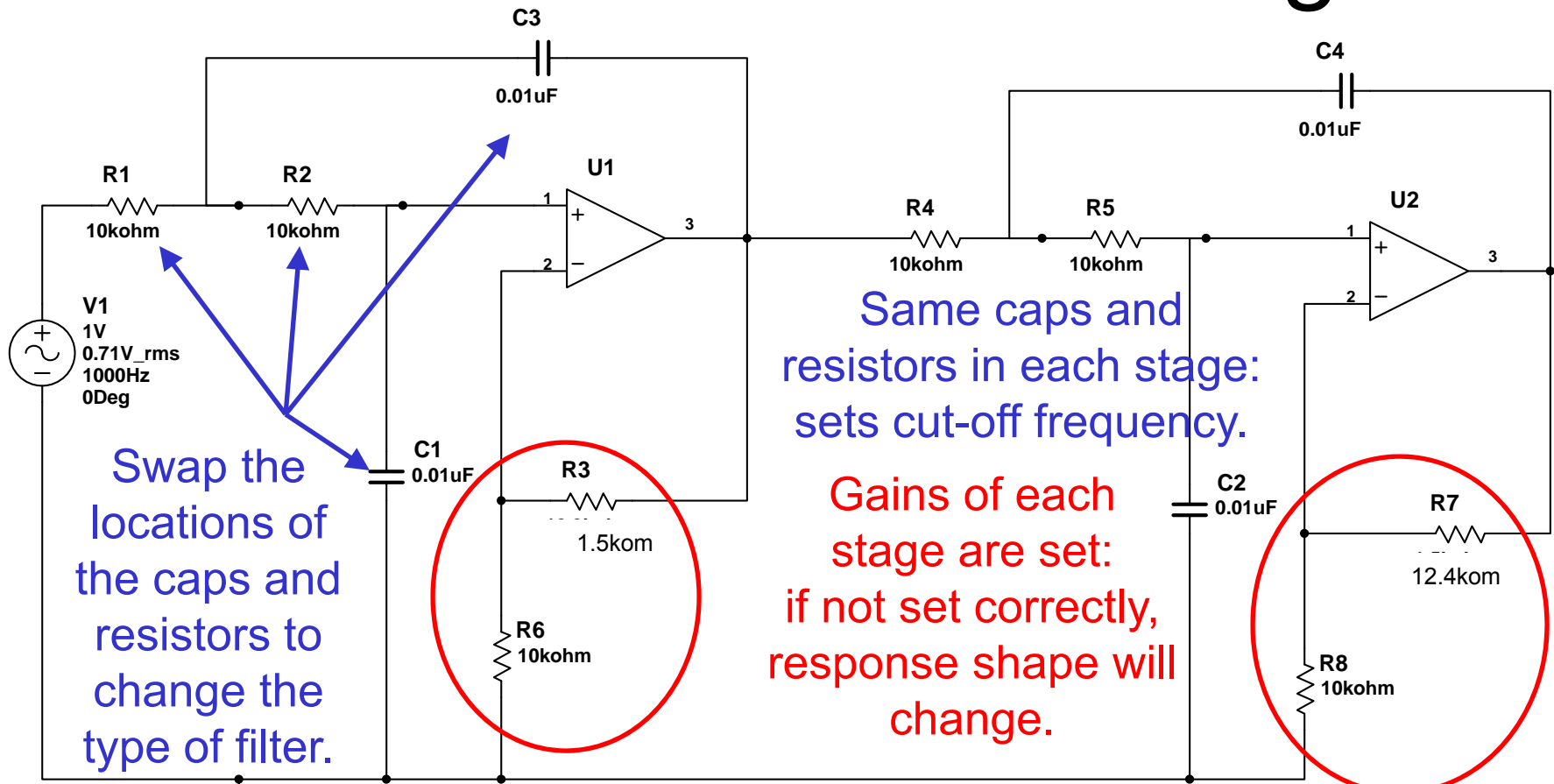

Swap the locations of the caps and resistors to change the type of filter.

Same caps and resistors in each stage: sets cut-off frequency.

Gains of each stage are set: if not set correctly, response shape will change.

Choose caps and resistors to adjust cut-off frequency. Use resistor in RC that is close to R_b

Different gains in each stage, as per design table.

Butterworth and Bessel Design

VCVS Low-Pass Filter Design:

f_c is desired 3dB frequency
of total n-pole filter

6 – pole Active Filter:

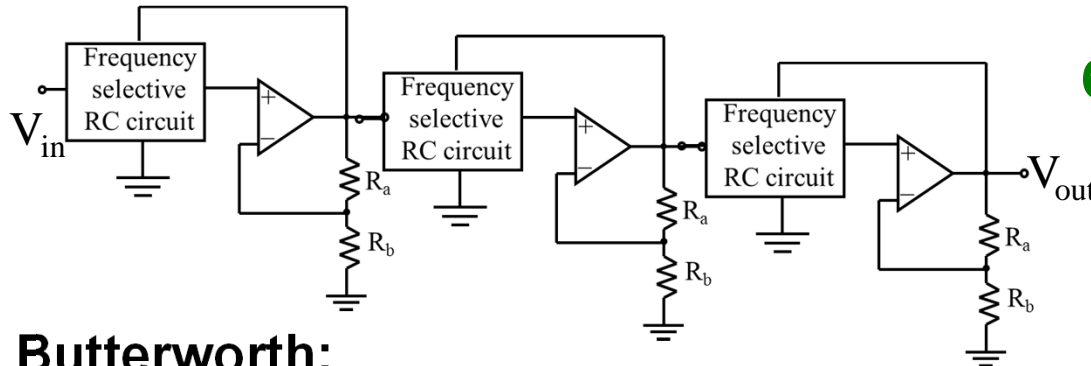

	Butterworth	Bessel
Poles	K	f_n K
2	1.59	1.27 1.27
4	1.15	1.43 1.08
6	2.24	1.61 1.76
6	1.07	1.61 1.04
	1.59	1.69 1.36
	2.48	1.91 2.02

Butterworth:

RC circuit is the same for all stages
Only the gain changes for each stage

$$RC = 1/(2\pi f_c) \quad \text{and} \quad R_a = (K_n - 1)R_b$$

Bessel:

RC circuit and gain change for each stage.

$$RC = 1/(2\pi f_n f_c) \quad \text{and} \quad R_a = (K_n - 1)R_b$$

4th Order Butterworth versus Bessel

2-stage (4-pole) Filter designs:

Poles	Stage(n)	Butterworth	Bessel	
		K_n	f_n	K_n
4	1	1.15	1.43	1.08
	2	2.24	1.61	1.76

Butterworth:

$$R_1 C_1 = R_2 C_2 = 1/(2\pi f_c)$$

$$R_{a1} = (K_1 - 1)R_{b1} = (1.15 - 1)R_{b1}$$

$$R_{a2} = (K_2 - 1)R_{b1} = (2.24 - 1)R_{b2}$$

Bessel:

$$R_1 C_1 = 1/(2\pi f_1 f_c) = 1/(2\pi(1.43)f_c)$$

$$R_2 C_2 = 1/(2\pi f_2 f_c) = 1/(2\pi(1.61)f_c)$$

$$R_{a1} = (K_1 - 1)R_{b1} = (1.08 - 1)R_{b1}$$

$$R_{a2} = (K_2 - 1)R_{b1} = (1.76 - 1)R_{b2}$$

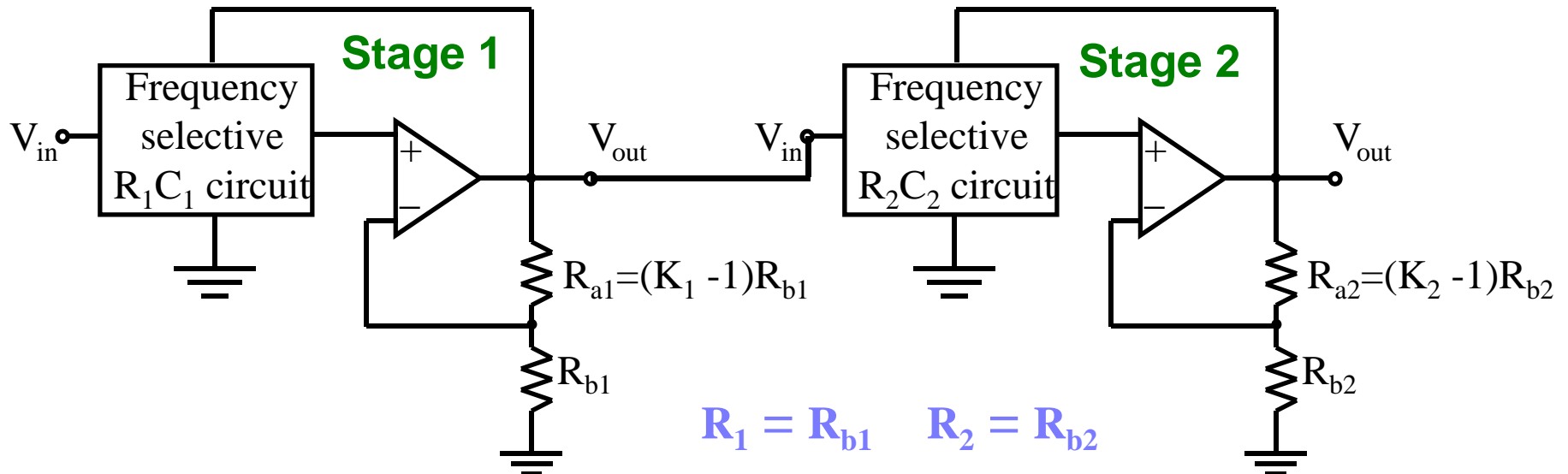

Higher Order Active Filter Circuits

The Butterworth, Chebyshev, and Bessel are active VCVS filter designs

- Made up of resistors, capacitors, and op-amps
- Each has its advantages and disadvantages (next slide)

Advantages of all high order active filters

- High Z_{in} and low Z_{out} mean good isolation of source and load
- Smaller number of parts and less expensive than inductors at low f
- Ease of adjustability over a wide frequency range
- Small spread of parts values
- Not a demanding use of the op-amps capabilities
 - **Such as slew rate, bandwidth, and output impedance**
- Op-amp provides gain
- Ability to make high-Q filters (sharp responses)

Disadvantages of active filters

- Sensitive to component values (a drawback of these circuits)
- Requires dc power supply (Both positive and negative)
- Limited ultimately by frequency response of op-amp.

Butterworth, Bessel, and Chebyshev Filters

Different filter designs to meet different filtering needs.

– Butterworth filter

f_c is -3dB point

GOOD - Maximally flat in passband

BAD - Poor phase (highly non-linear phase response with frequency)

BAD - Poor step time response (overshoot)

$$f_c = \frac{1}{2\pi RC}$$

– Bessel filter

f_c is -3dB point

GOOD - Smooth time response (Critically damped step response)

BAD - Flat phase response (linear phase shift with freq)

BAD - Slow roll off at f_c

$$f_c = \frac{1}{2\pi f_n RC}$$

– Chebyshev filter

f_c is end of pass band (not -3dB point)

GOOD- Sharp initial roll-off at f_c

Still falls with slope = order at high f

GOOD - Similar design rules to Bessel

BAD – Ripple in passband

0.5dB and 2.0dB ripple versions

BAD - Poor phase response

BAD – Poor step response (overshoot)

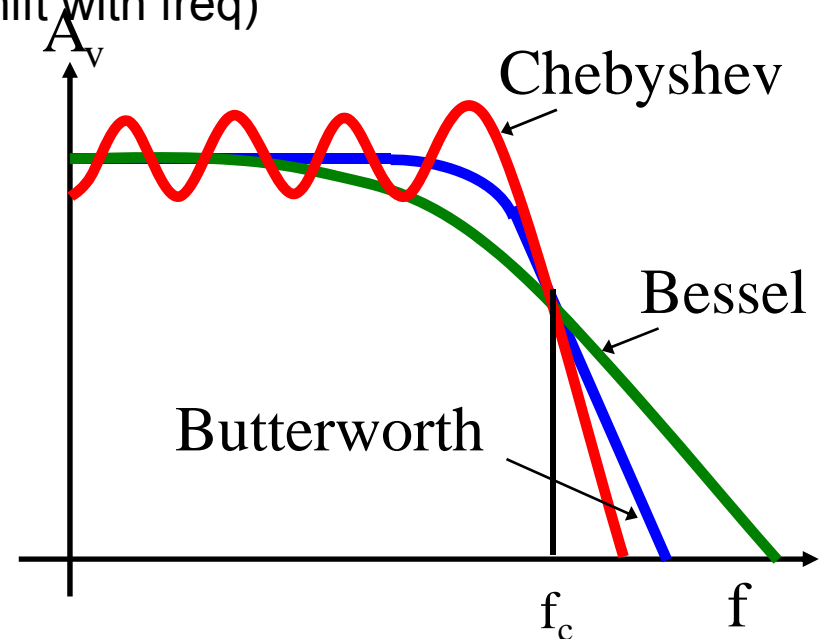

Higher Order Filters Compared

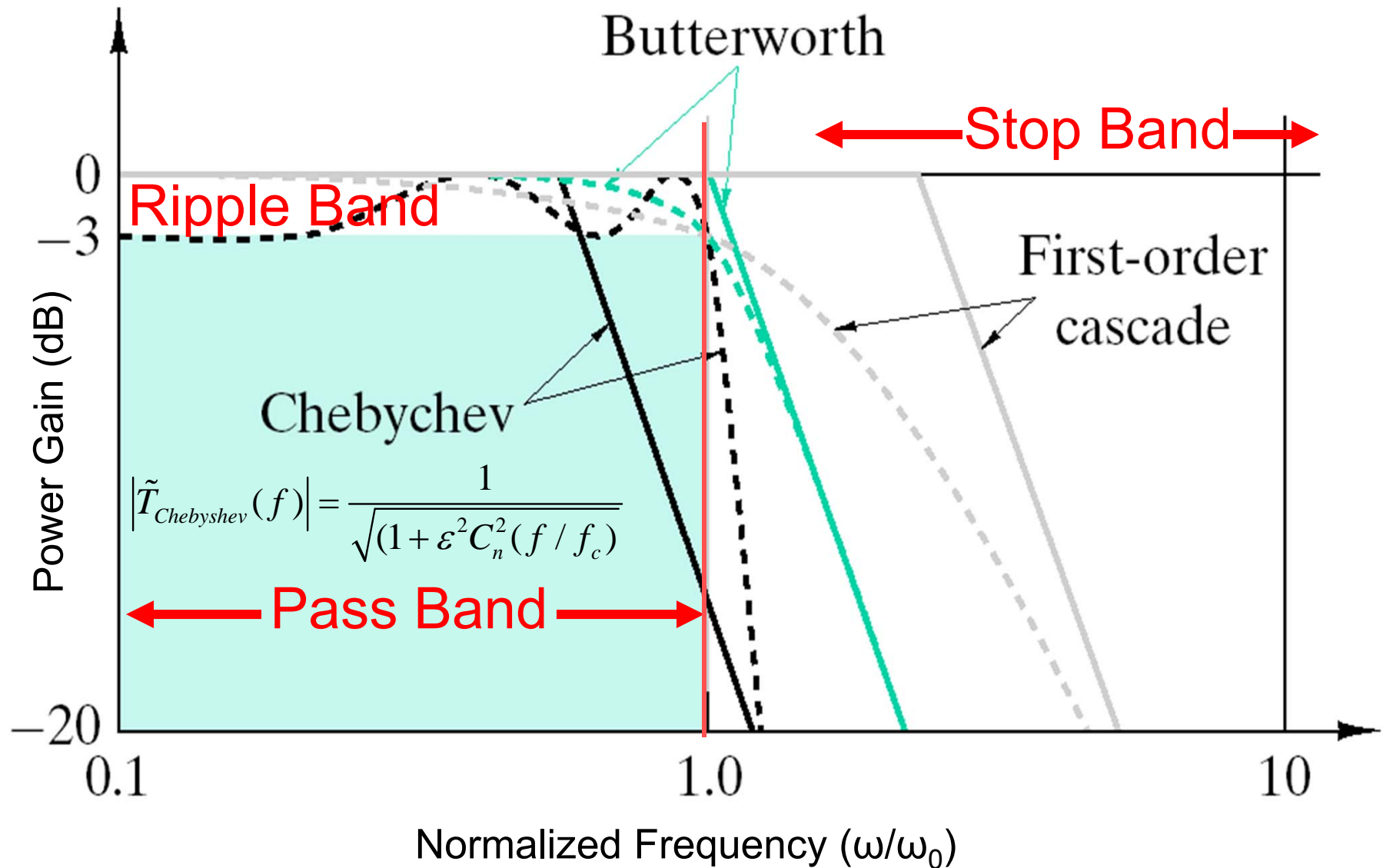

Temporal step response of filters

