

Today

- **2/22/11 Physics 262 Lecture 6**
- **Power Supplies and Regulators**
 - Transformers
 - Rectifiers
 - Power supplies and regulators
- **Reading**
 - Reread 28-29 (1.17) and 44-48 (1.25-1.29)
 - Read 52 (1.31), 307-311 (6.01-6.02) and 325-333
- **Homework due 3/1**
 1. Exercises 1.27 (p. 46), 6.1 (p. 311), and chapter 6 additional exercise 1 (p. 384)
 2. Choose a filter capacitor BFPS supplied by a 10:1 transformer with 120 V_{rms} input voltage to the transformer has less than 0.5V peak to peak ripple.
 3. A 1:2 transformer is supplied with $V_{\text{rms}} = 120\text{V}$ input and has a 1k ohm load. What are the power dissipated into load, the RMS voltage on load, and the peak current in the primary and the secondary coils?
 4. The typical line AC voltage of $V_{\text{rms}} = 120\text{V}$ followed by with a 1:20 turn ratio transformer supplies a BFPS (with typical 0.6V diodes) and 500 ohm load and 1mF capacitor. What is the output ripple?
- **Lab**
 - Lab 5 Power supplies
 - Do pre-lab BEFORE lab
 - Lab 4 write-up due Friday at 10am

Transformer

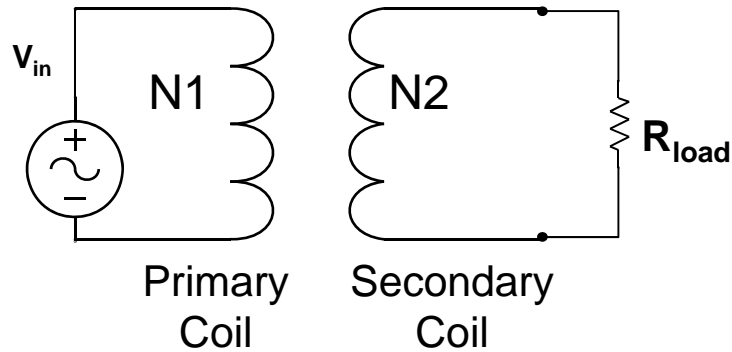

$$\text{Turn Ratio} = \frac{N_2}{N_1}$$

A.k.a $N_2:N_1$

$$P_{out} = P_{in} \quad i_{out} = \frac{N_1}{N_2} i_{in} \quad V_{out} = \frac{N_2}{N_1} V_{in}$$

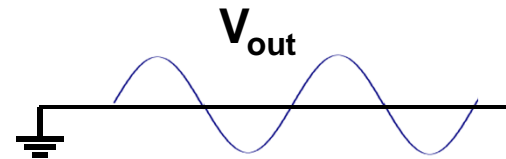
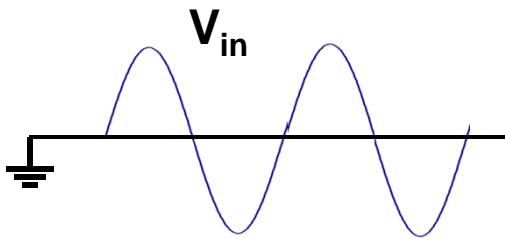

Bridge Rectifier

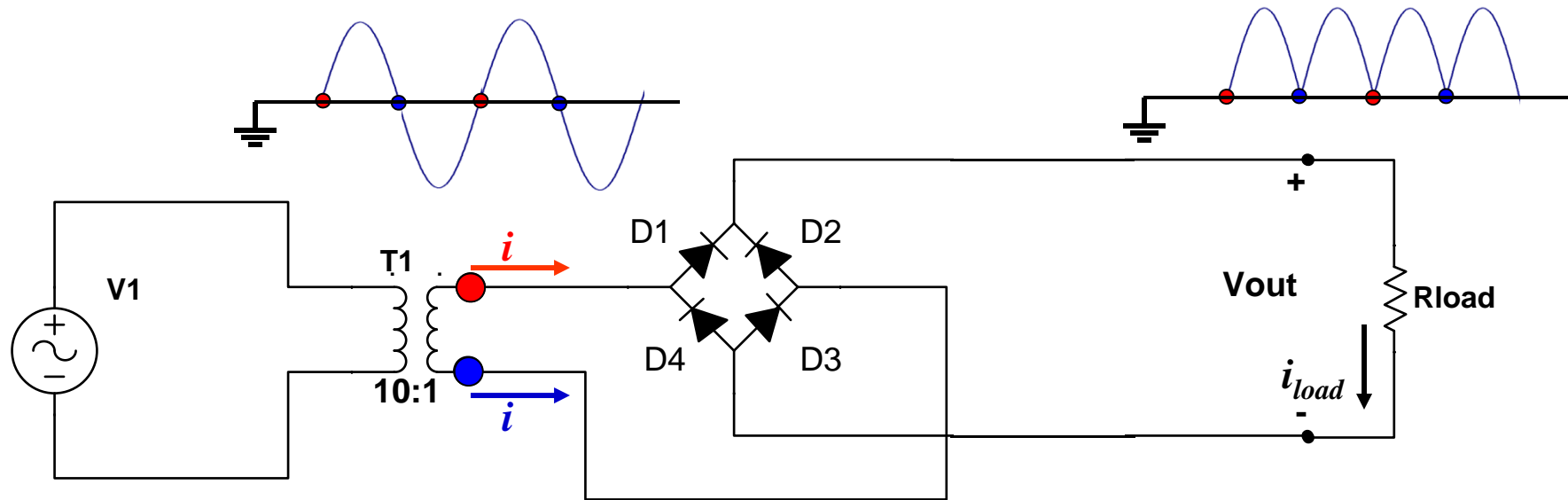

Positive half-cycle: Current flows through D_1 , R_{load} and D_3

Negative half-cycle: Current flows through D_2 , R_{load} and D_4

Note in both directions, there are two diode voltage drops

Brute Force Power Supply

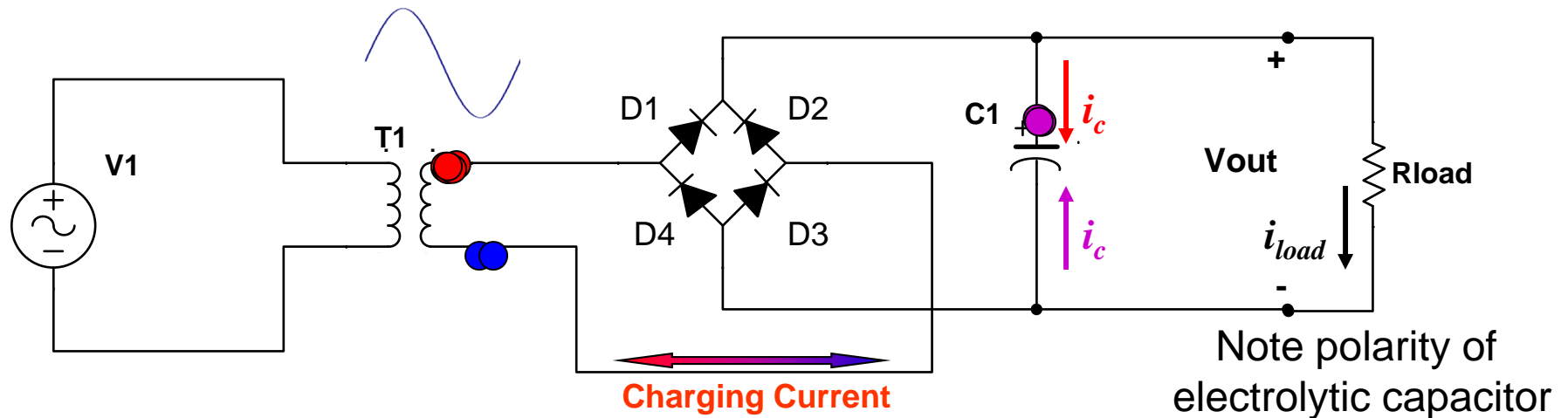
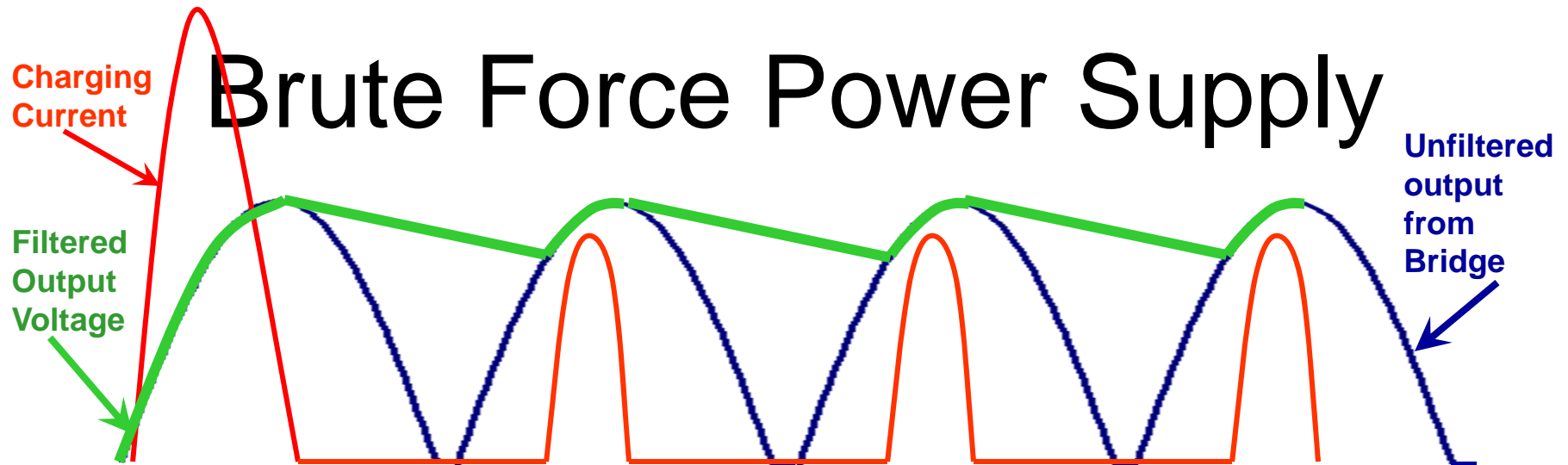

The output is the amplitude of the input, divided by the turns ratio of the transformer minus drop across the rectifier diodes.

$$V_{Out_max} = (N_2 / N_1) V_{AC_in_max} - 2V_{diode}$$

Ripple Voltage

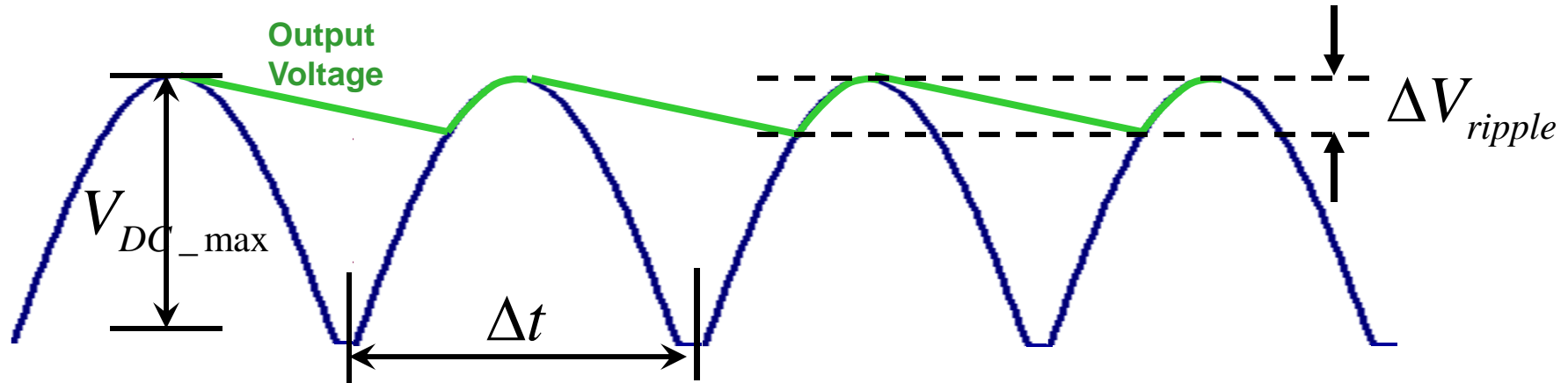

For small ripple, $V_{DC} \sim V_{DC_max}$

$$i = C \frac{dV}{dt} \quad \Delta V_{ripple} = \frac{i \Delta t}{C} = \frac{V_{DC} \Delta t}{RC}$$

BFPS has filter capacitor, C

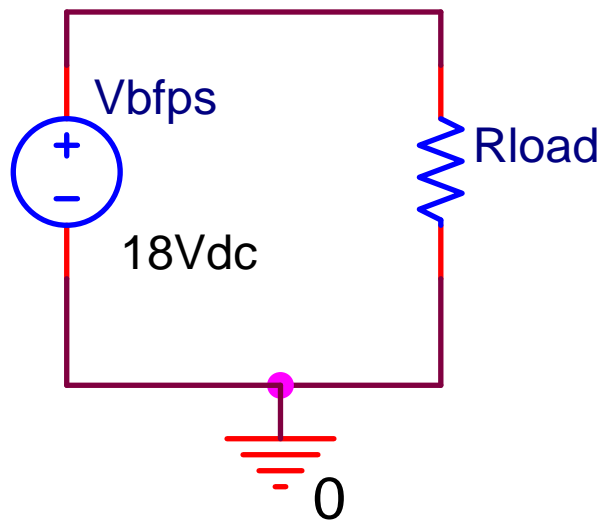

$$\text{Let } R_{LOAD} = 1k\Omega, \Delta t = \frac{1}{120Hz}, C = 1000\mu F$$

$$\Delta V_{ripple} = \frac{18V}{120 \cdot 1k\Omega \cdot 1000\mu F} = 0.15V_{DC}$$

Load and Line Regulation

load regulation

“Change in output voltage or current for any load change within ratings”

line regulation:

“Change in output voltage or current for any line change within ratings.”

BFPS has Poor Load Regulation

Parasitic resistance associated with the elements in the circuit all contribute to a relatively large Thévenin equivalent resistance.

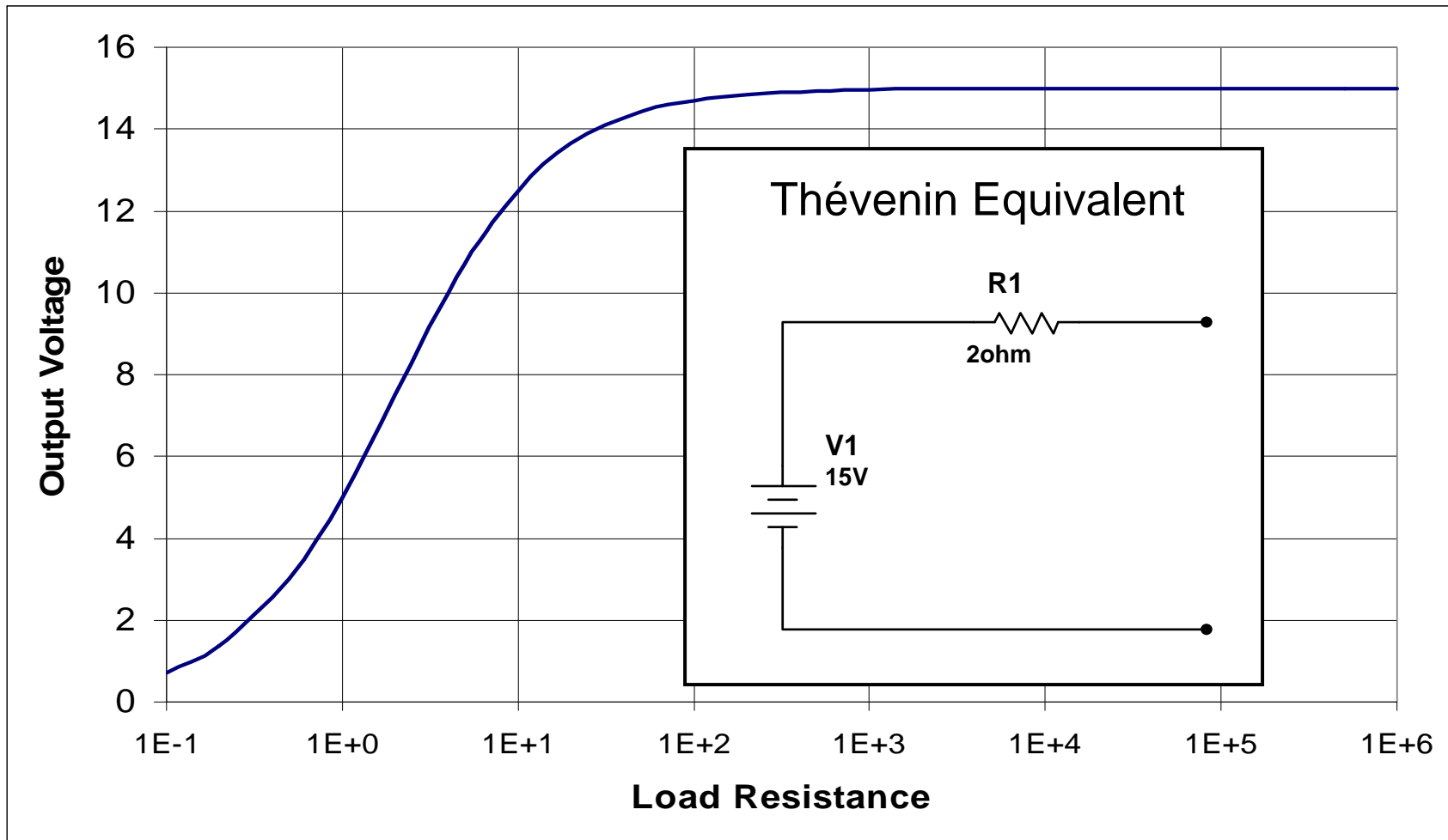

BFPS has Poor Line Regulation

Changes in line voltage propagate directly through to the load.

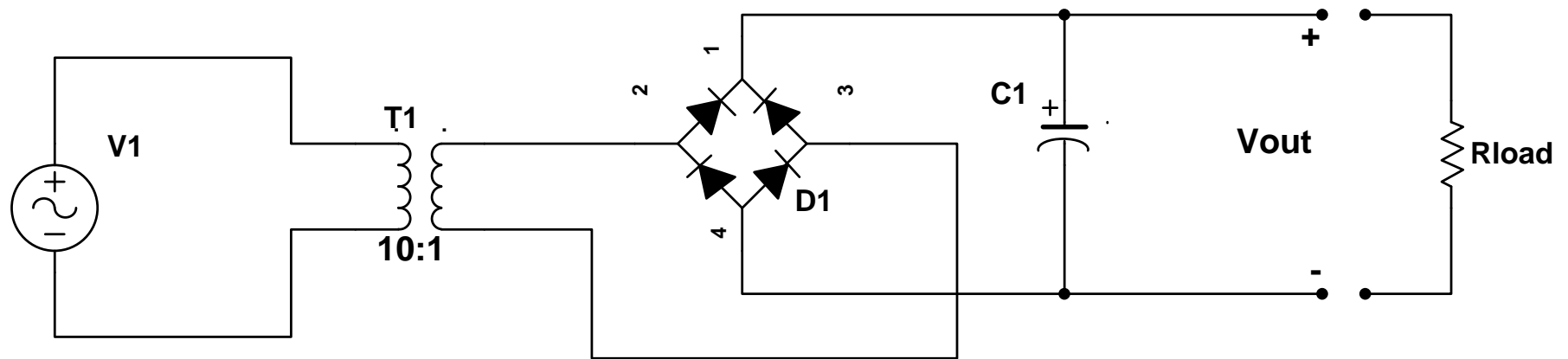

$$V_{DC_out} \approx V_{AC_line} \cdot T_{ratio} - 2V_{diode}$$

Summary of BFPS Characteristics

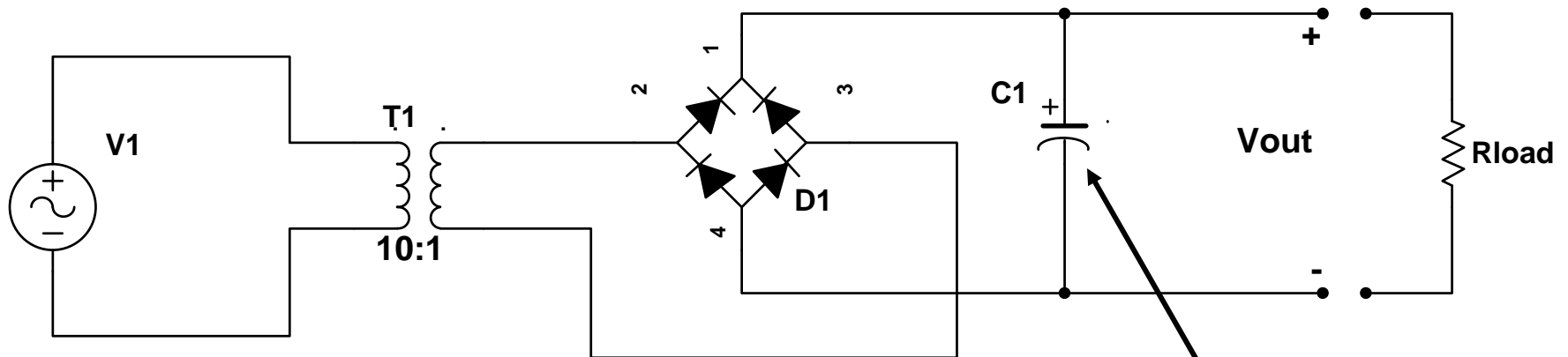

- Large ripple voltage amplitude
- Poor line and load regulation
- High current capacity (“ampacity”)
- Inexpensive

“Bulk” DC

Regulated DC Supply

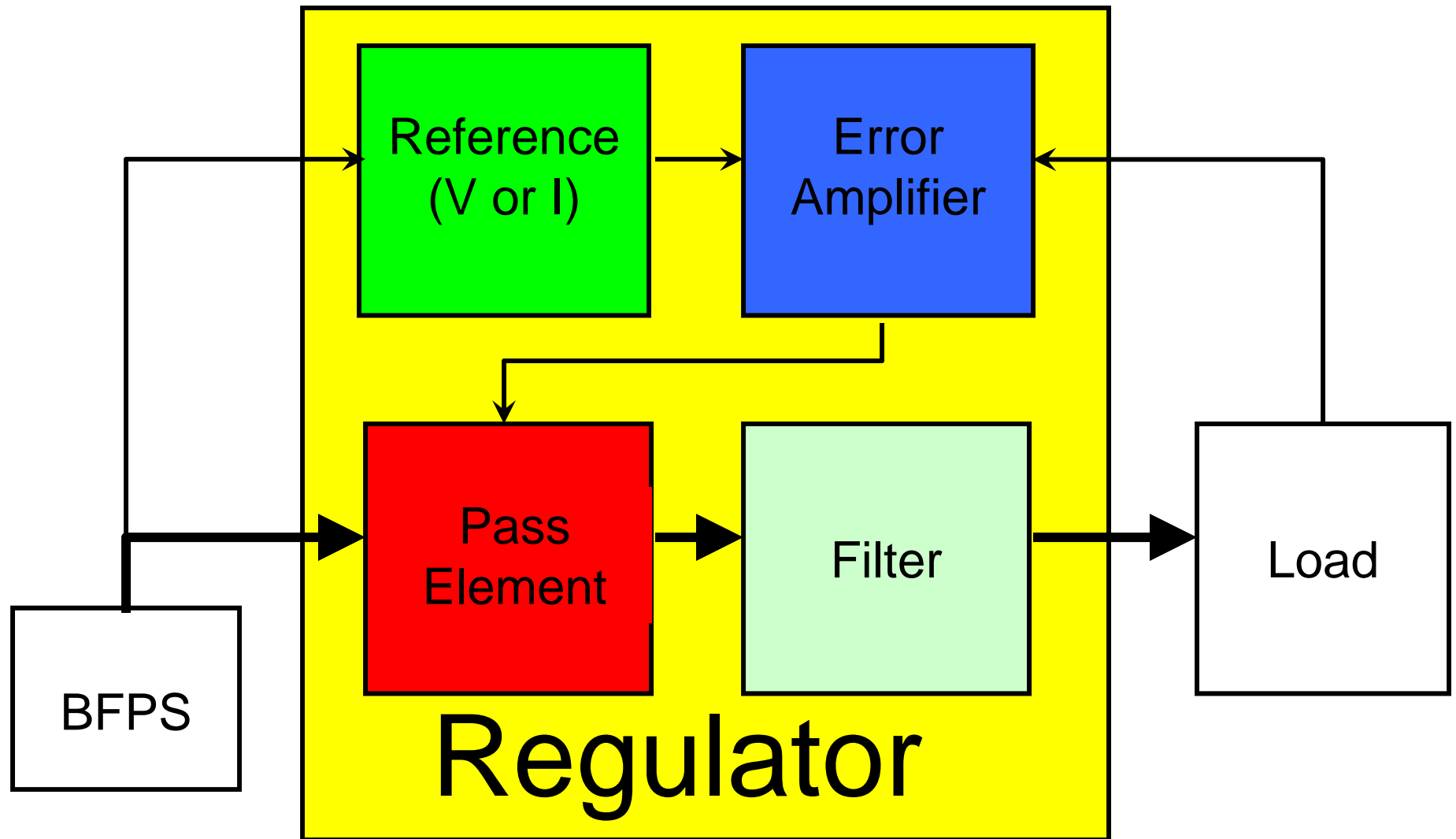

Basic Positive Linear Regulator

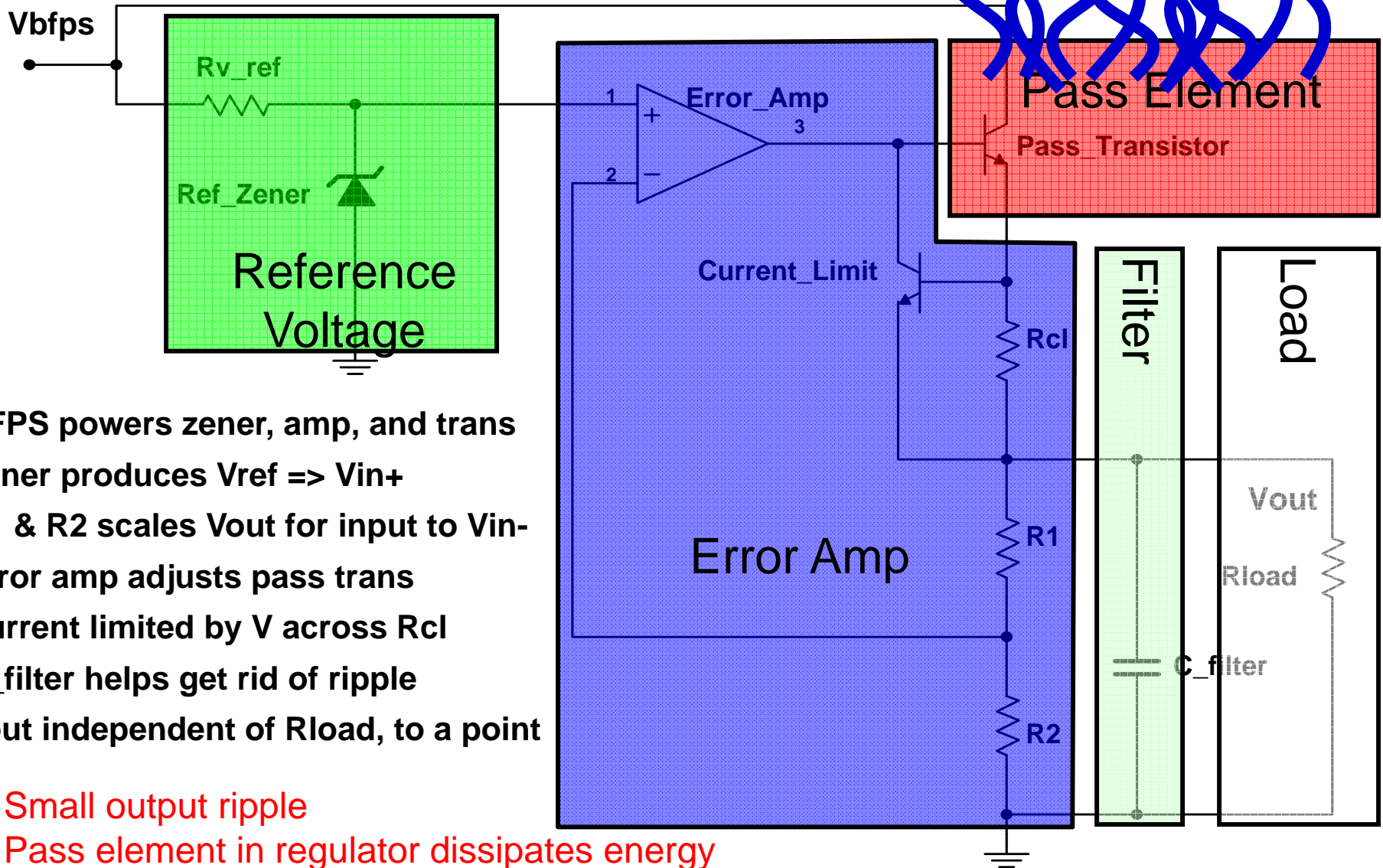

- BFPS powers zener, amp, and trans
- Zener produces $V_{ref} \Rightarrow V_{in+}$
- R1 & R2 scales V_{out} for input to V_{in-}
- Error amp adjusts pass trans
- Current limited by V across Rcl
- C_filter helps get rid of ripple
- V_{out} independent of R_{load} , to a point

- Small output ripple
- Pass element in regulator dissipates energy

723 Regulator

functional block diagram

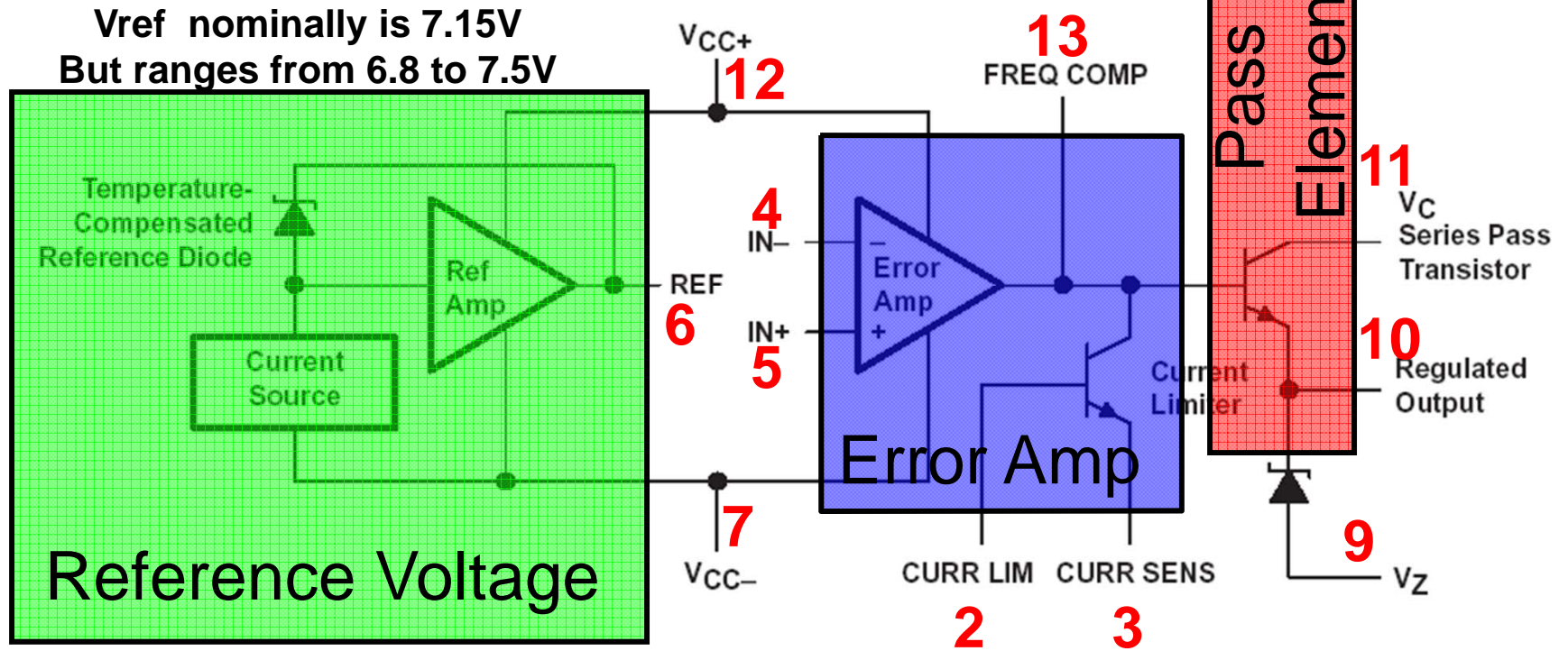

**No Connection
Pins 1, 8 and 14**

**$V_c > V_{reg} + 3V$
and $V_c > 9.5V$ to power reference**

723 Regulator Plus Power Pass Transistor

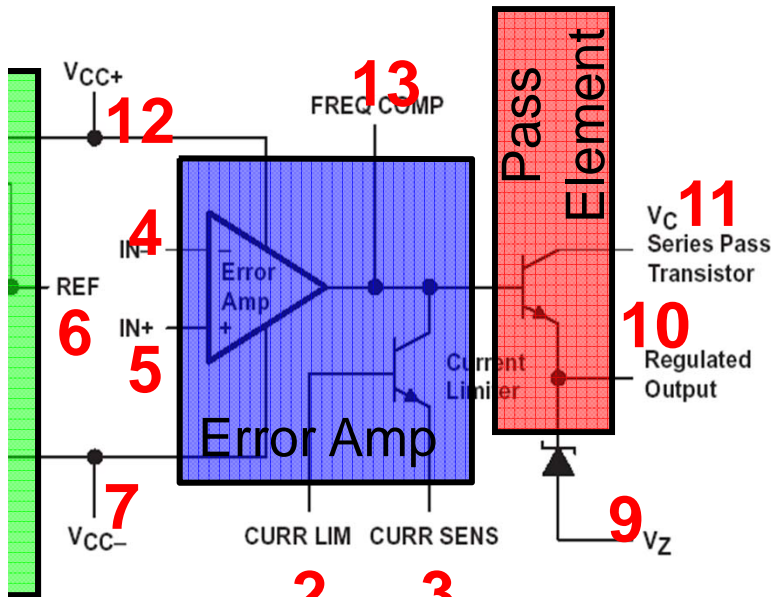

LM723 Regulator

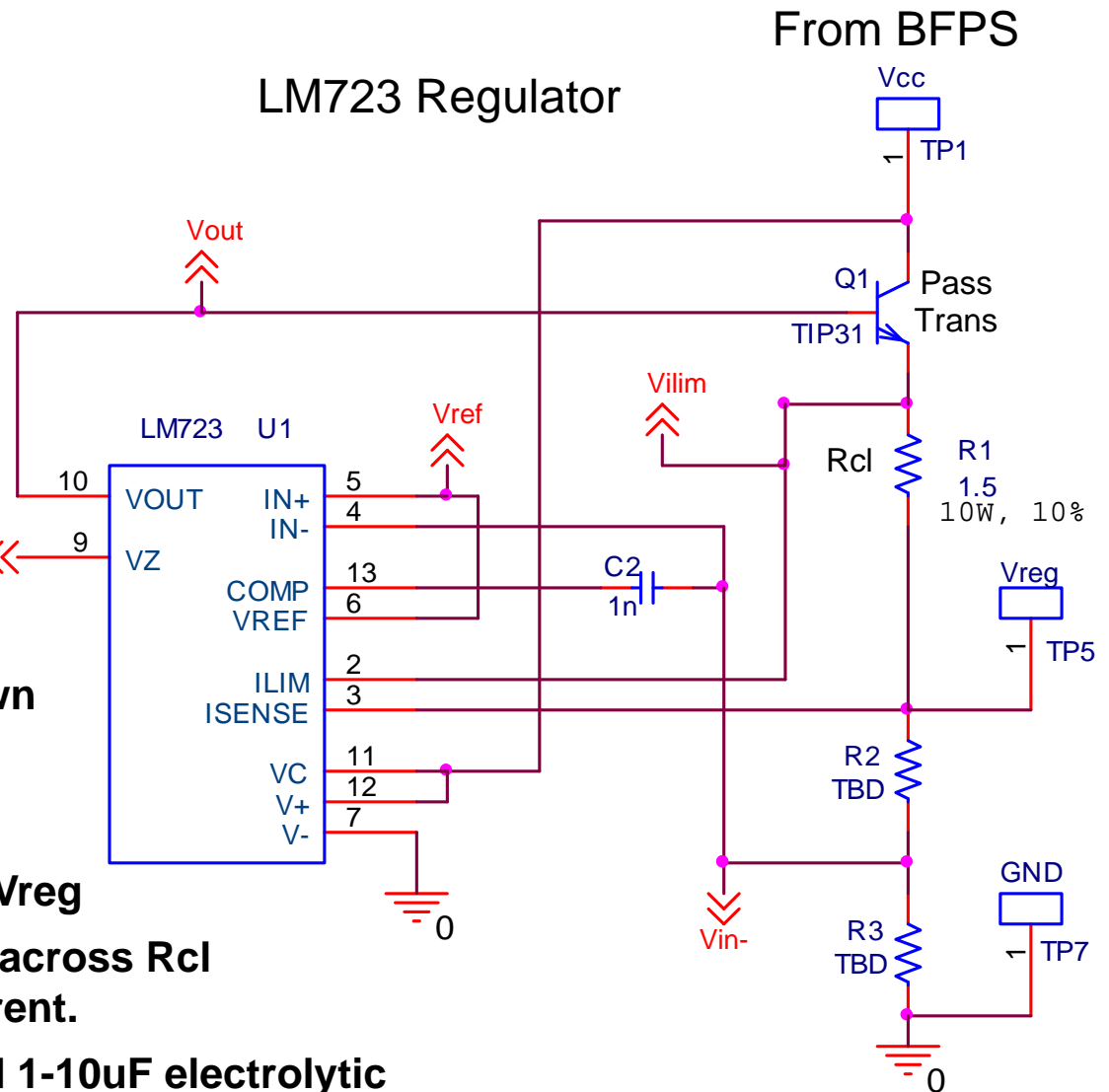

- BFPS supplies Pass Trans and 723
- R2 & R3 scale Vreg for input to Vin-
For $V_{ref} > V_{out} > 2V$, divide V_{ref} down
- Vref goes into Vin+
- 723 Vout turns on power Pass Trans
- Power pass trans supplies current to Vreg
- Pass Trans current limited by voltage across Rcl
Set for 0.5V across Rcl at max current.
- Add C_filter of 0.01-0.1uF ceramic and 1-10uF electrolytic

CV and CC Modes

5Vdc Source

IV diagrams

DC voltage source

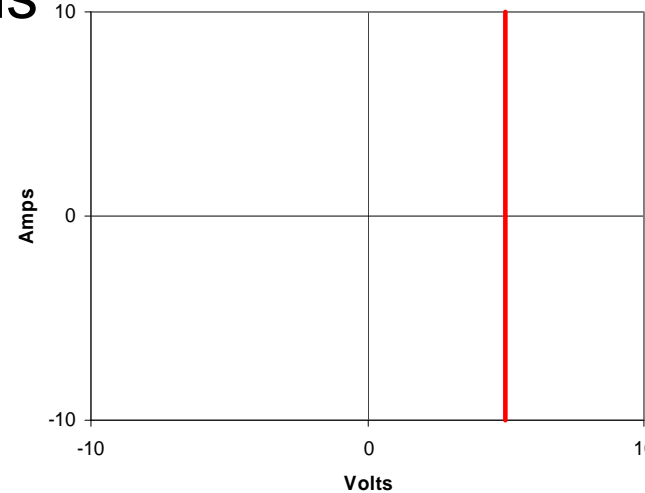
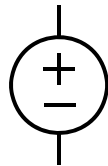

5A dc Source

DC Current Source

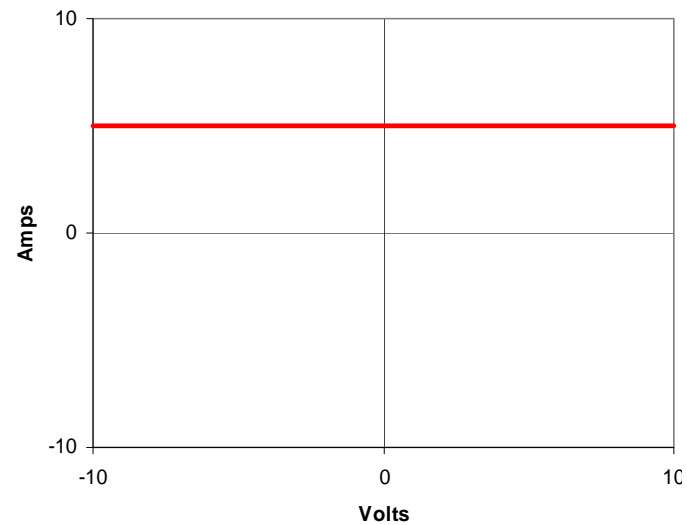
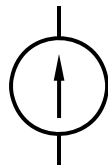

Practical Voltage/Current Source

Most laboratory supplies will “fold back” from constant voltage mode into *constant current* as required by the load. The point at which the supply converts from constant voltage to constant current is often controllable.

Ideal CV supply can source infinite current.

Lab source folds back at the current limit set point, and is then said to be operating in “constant current” mode.

Practical CV supply is generally protected by limiting output power. Could include “*crowbar*.”

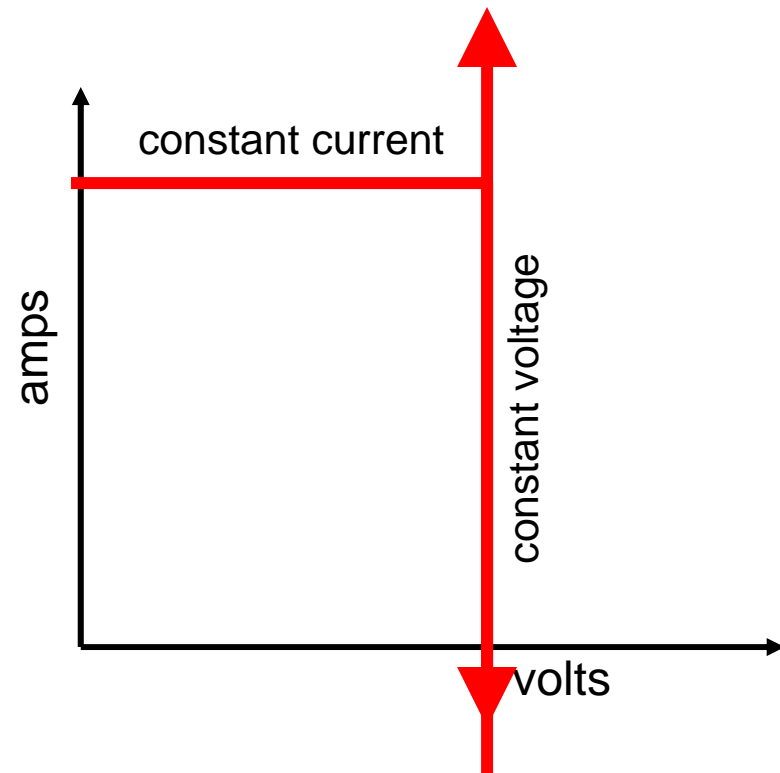

References

1. Paul Horowitz and Winfield Hill (1989). "The Art of Electronics," 2nd Ed., Cambridge
2. Roland E. Thomas and Albert J. Rosa (1998). "The Analysis and Design of Linear Circuits," 2nd Ed., Prentice Hall
3. Abraham I. Pressman (1998). "Switching Power Supply Design," 2nd Ed., McGraw-Hill
4. Service Guide Agilent E3631A DC Power Supply
<http://cp.literature.agilent.com/litweb/pdf/E3631-90011.pdf>

Load Regulation

load re·gu·la·tion

1. "Change in output voltage or current for any load change within ratings"
2. \pm (% of output + offset)

$$V_{\text{line}} = 115 \pm 10\% \text{ VAC}$$

Load Regulation for the Agilent E3631A:

Voltage $<0.01\% + 2 \text{ mV}$

Current $<0.01\% + 250 \mu\text{A}$

Output Ratings (@ 0 °C - 40 °C)

+6V Output 0 to +6 V ; 0 to 5 A

+25V Output 0 to +25 V ; 0 to 1 A

-25V Output 0 to -25 V ; 0 to 1 A

$$V_{\text{out}} := 25\text{V}$$

$$\Delta v := V_{\text{out}} \cdot 0.0001 + 2\text{mV}$$

$$V_{\text{min}} := V_{\text{out}} - \Delta v \quad V_{\text{min}} = 24.995 \text{ V}$$

$$V_{\text{max}} := V_{\text{out}} + \Delta v \quad V_{\text{max}} = 25.005 \text{ V}$$

Line Regulation

line re·gu·la·tion:

1. "Change in output voltage or current for any line change within ratings."
2. $\pm(\% \text{ of output} + \text{offset})$

$$V_{\text{line}} = 115 \pm 10\% \text{ VAC}$$

Line regulation for the Agilent E3631A:

Voltage $<0.01\% + 2 \text{ mV}$

Current $<0.01\% + 250 \mu\text{A}$

AC Input Rating (line): $115\text{V}_{\text{rms}} \pm 10\%$

Power Supply Terminology I

Performance Specifications

Output Ratings (@ 0 °C - 40 °C)

+6V Output	0 to +6 V ; 0 to 5 A
+25V Output	0 to +25 V ; 0 to 1 A
-25V Output	0 to -25 V ; 0 to 1 A

Programming Accuracy^[1] 12 months (@ 25 °C ± 5 °C), ±(% of output + offset)

	<u>+6V Output</u>	<u>+25V Output</u>	<u>-25V Output</u>
Voltage	0.1% + 5 mV	0.05% + 20 mV	0.05% + 20 mV
Current	0.2% + 10 mA	0.15% + 4 mA	0.15% + 4 mA

Readback Accuracy^[1] 12 months (over GPIB and RS-232 or front panel with respect to actual output @ 25 °C ± 5 °C), ±(% of output + offset)

	<u>+6V Output</u>	<u>+25V Output</u>	<u>-25V Output</u>
Voltage	0.1% + 5 mV	0.05% + 10 mV	0.05% + 10 mV
Current	0.2% + 10 mA	0.15% + 4 mA	0.15% + 4 mA

Power Supply Terminology II

Ripple and Noise (with outputs ungrounded, or with either output terminal grounded, 20 Hz to 20 MHz)

	<u>+6V Output</u>	<u>+25V Output</u>	<u>-25V Output</u>
Voltage	<0.35 mV rms <2 mV p-p	<0.35 mV rms <2 mV p-p	<0.35 mV rms <2 mV p-p
Current	<2 mA rms	<500 μ A rms	<500 μ A rms
Common mode current	<1.5 μ A rms		

Load Regulation, \pm (% of output + offset)

Change in output voltage or current for any load change within ratings

Voltage	<0.01% + 2 mV
Current	<0.01% + 250 μ A

Line Regulation, \pm (% of output + offset)

Change in output voltage and current for any line change within ratings

Voltage	<0.01% + 2 mV
Current	<0.01% + 250 μ A

Power Supply Terminology III

Programming Resolution

	<u>+6V Output</u>	<u>+25V Output</u>	<u>-25V Output</u>
Voltage	0.5 mV	1.5 mV	1.5 mV
Current	0.5 mA	0.1 mA	0.1 mA

Readback Resolution

	<u>+6V Output</u>	<u>+25V Output</u>	<u>-25V Output</u>
Voltage	0.5 mV	1.5 mV	1.5 mV
Current	0.5 mA	0.1 mA	0.1 mA

Meter Resolution

	<u>+6V Output</u>	<u>+25V Output</u>	<u>-25V Output</u>
Voltage	1 mV	10 mV	10 mV
Current	1 mA	1 mA	1 mA

Power Supply Terminology IV

Transient Response Time

Less than 50 μ sec for output recover to within 15 mV following a change in output current from full load to half load or vice versa

Command Processing Time

Programming Commands : Maximum time for output to change after receipt of APPLY and SOURce commands) : <50 msec

Readback Command : Maximum time to readback output by MEASure? command : <100 msec

The Other Commands : < 50 msec

Tracking Accuracy

The ± 25 V outputs track each other within $\pm(0.2\%$ of output + 20 mV).