

MOSES: The Instrument and The Math

CHARLES KANKELBORG
Physics Department
Montana State University

Applied Math Seminar
2004 February 26



Abstract



A pioneering remote sensing experiment is being developed at MSU: the *Multi-Order Solar Extreme Ultraviolet Spectrograph (MOSES)*. The *MOSES* rocket payload is scheduled for launch from White Sands Missile Range in August of this year. But the success of the mission hinges on what happens after the payload parachutes safely back to Earth: the mathematical and computational challenge of analyzing a new kind of data.



MOSES: Multi-Order Solar EUV Spectrograph



- NASA sounding rocket payload.
- Built at MSU, largely by students.
- Launch August 19, 2004 from WSMR.
- Extreme Ultraviolet (EUV) observations of the Sun
- Novel “snapshot” imaging spectrometer.
- Data interpretation: inverse problem





MOSES Team





MOSES Team

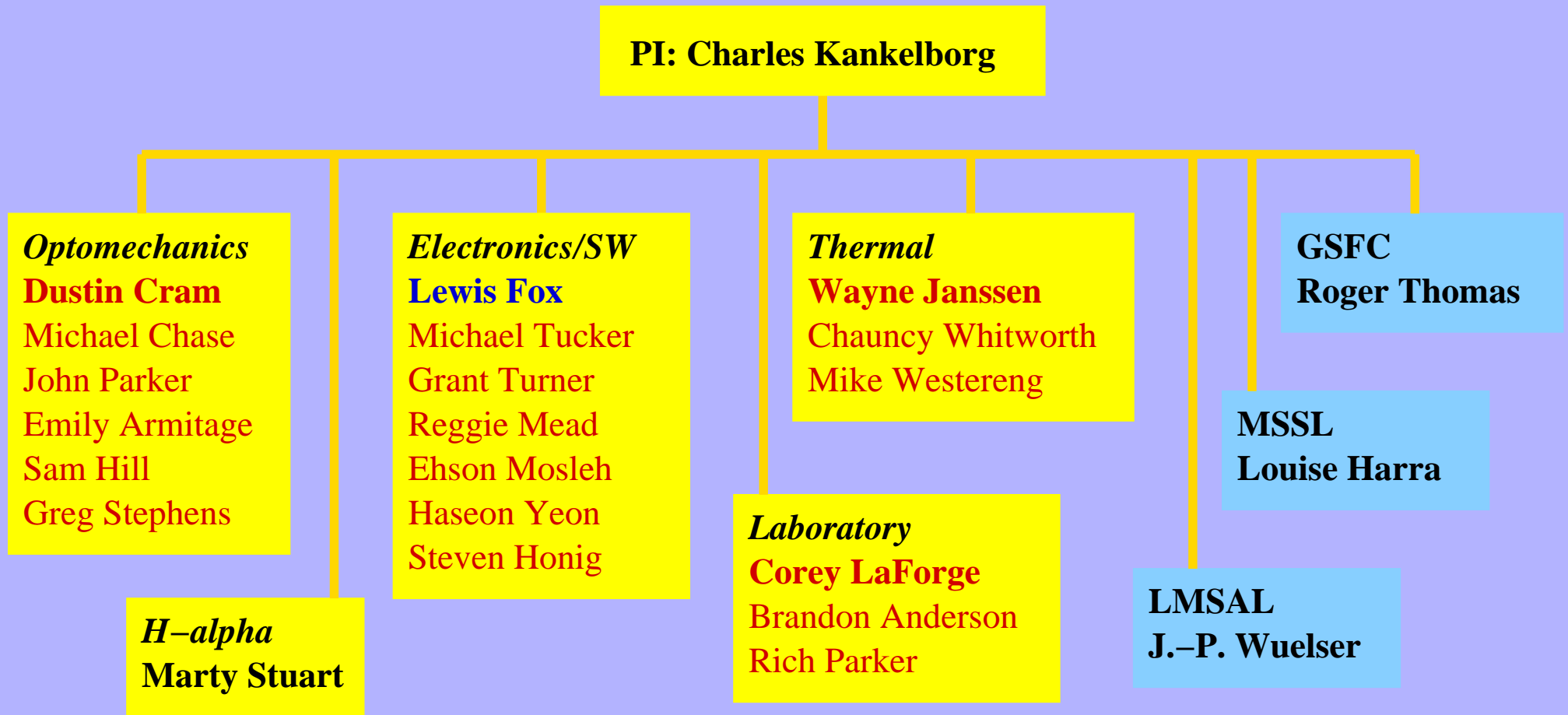

Suborbital Rocket (NASA's part)

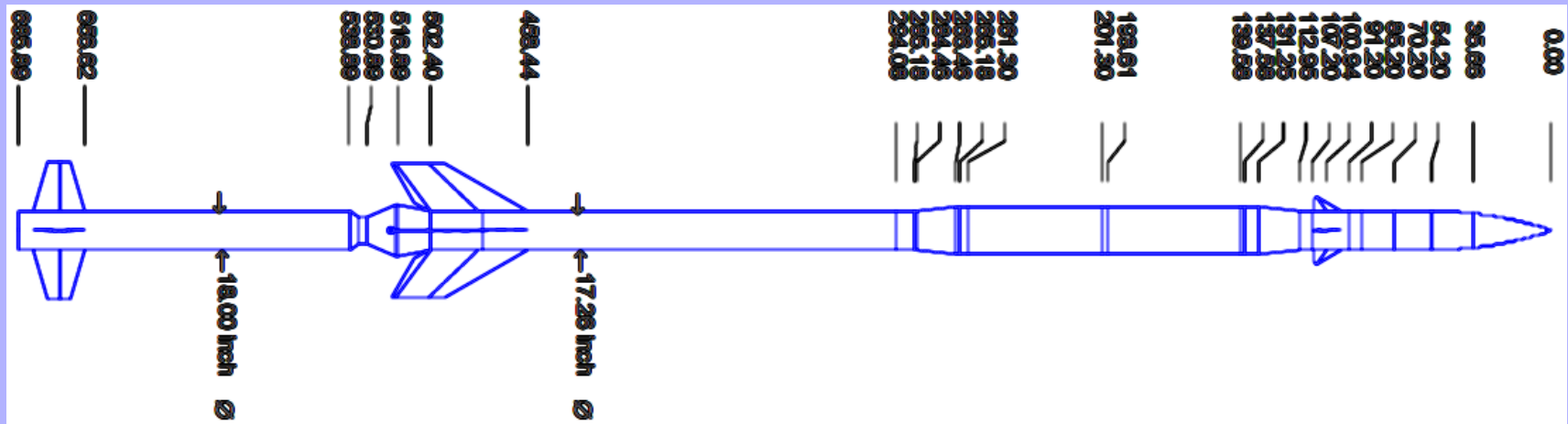

- Terrier booster, Black Brant VC sustainer
- Launch from White Sands Missile Range
- Apogee near 300 km
- 160 km upleg at 100 s; 300 s to obtain data
- Impact 80 km downrange

The Payload

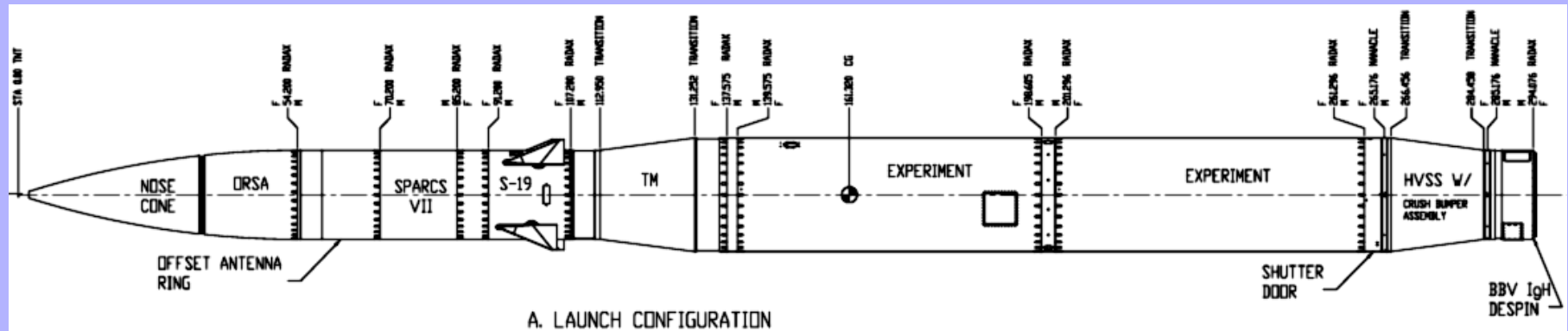

- Guidance, telemetry, solar pointing and recovery (NASA)
- Experiment section (our part!)

MOSES instrument layout

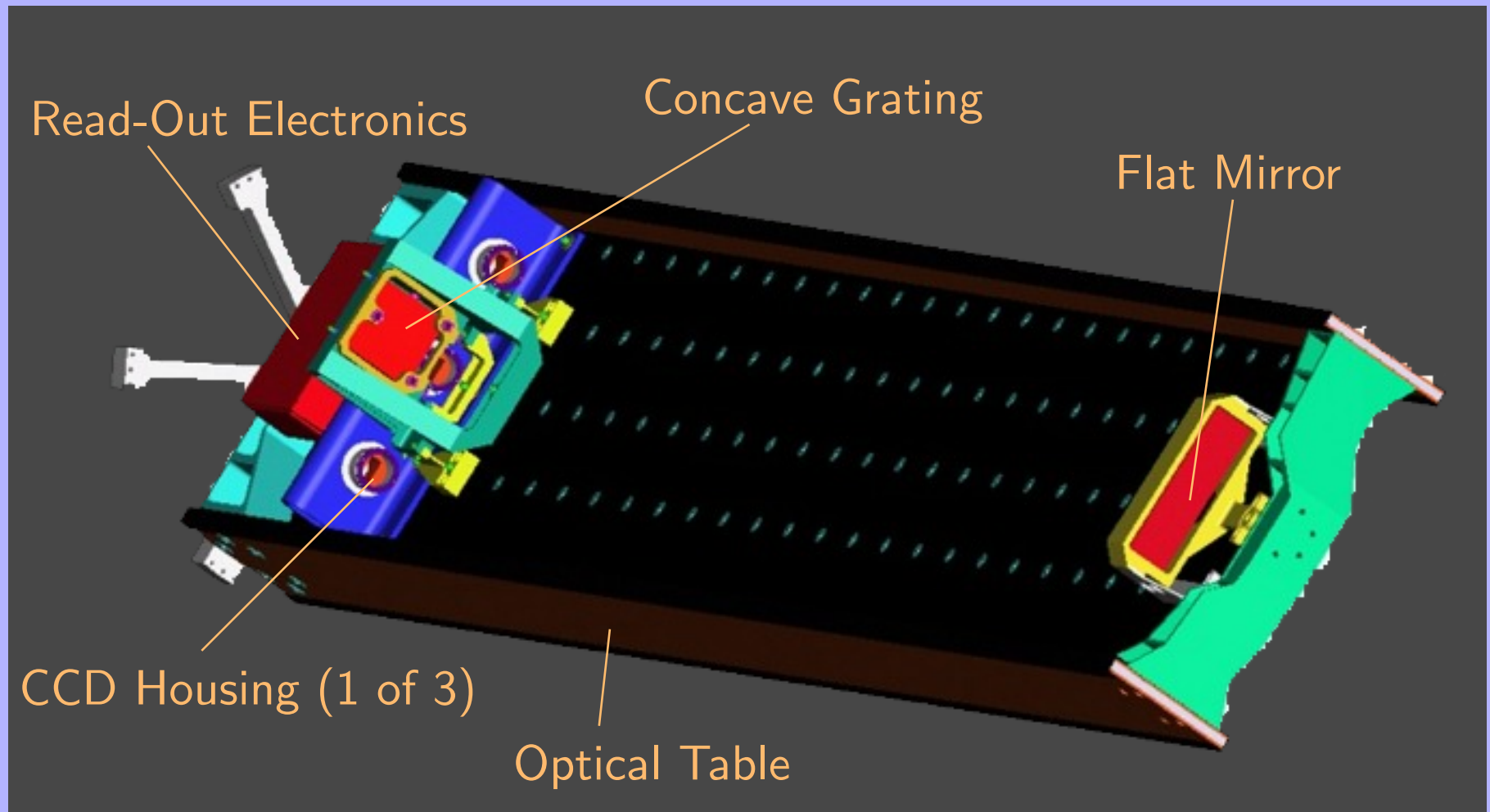

MOSES flight hardware

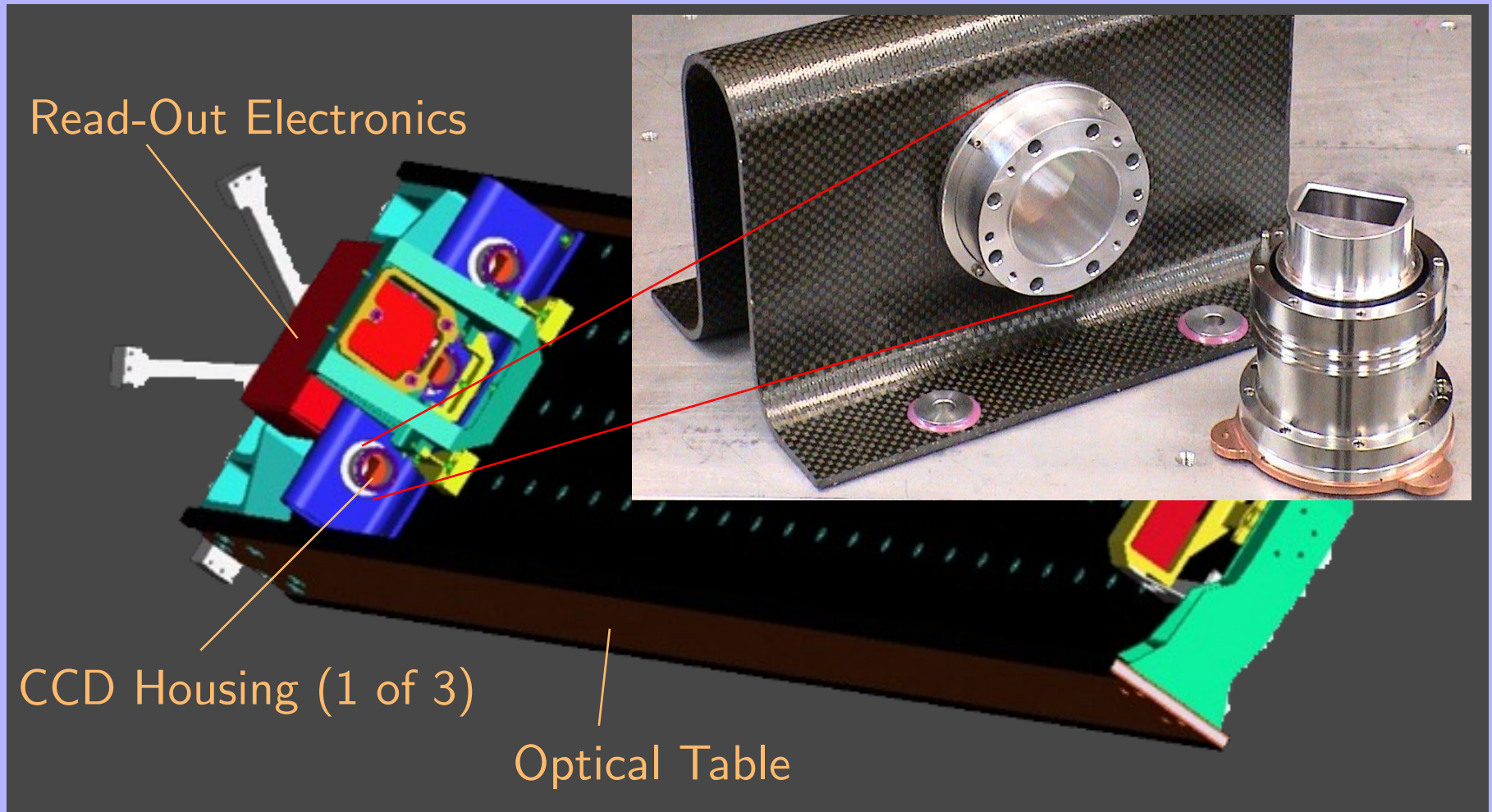

MOSES flight hardware

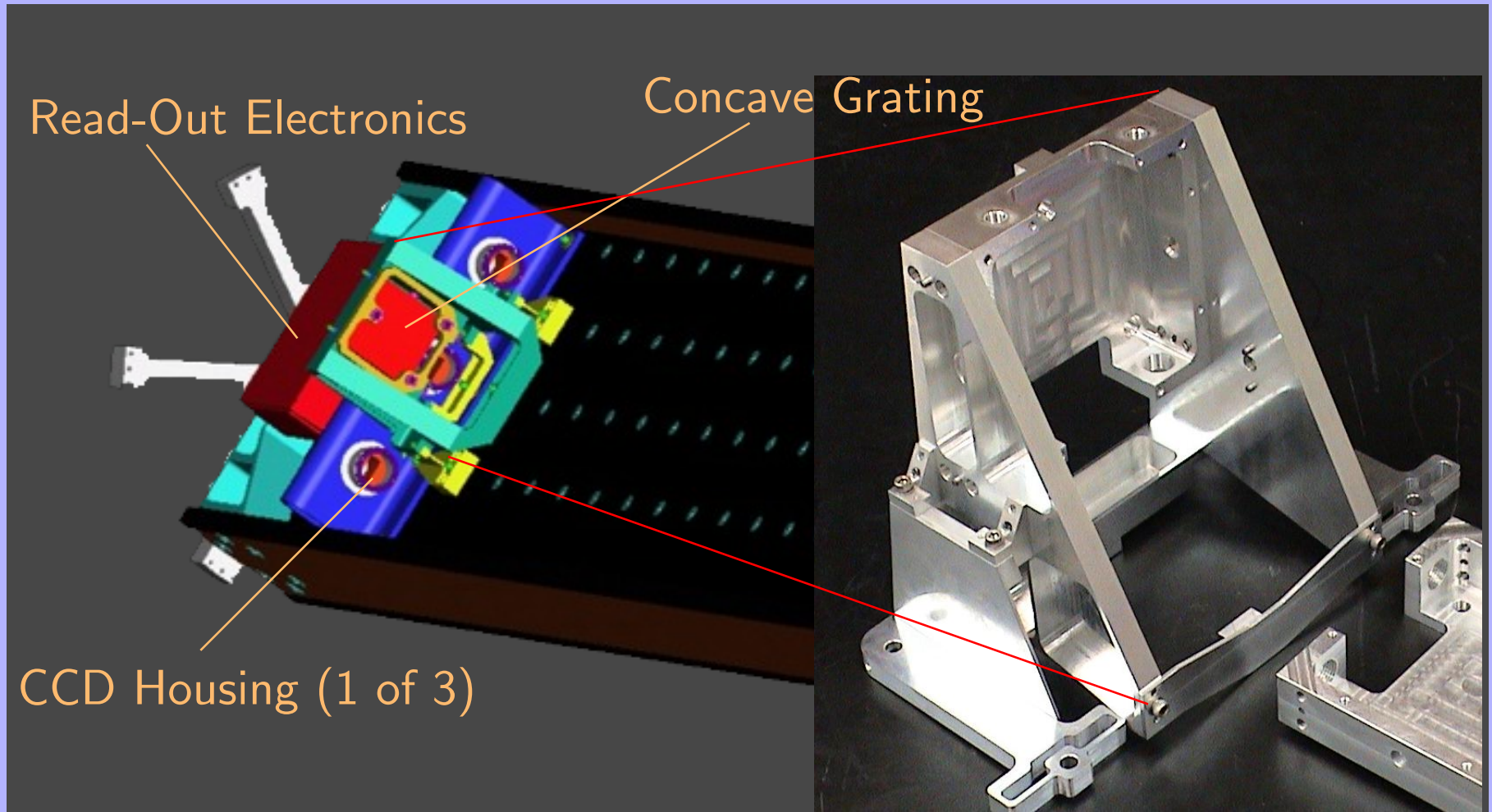

MOSES flight hardware

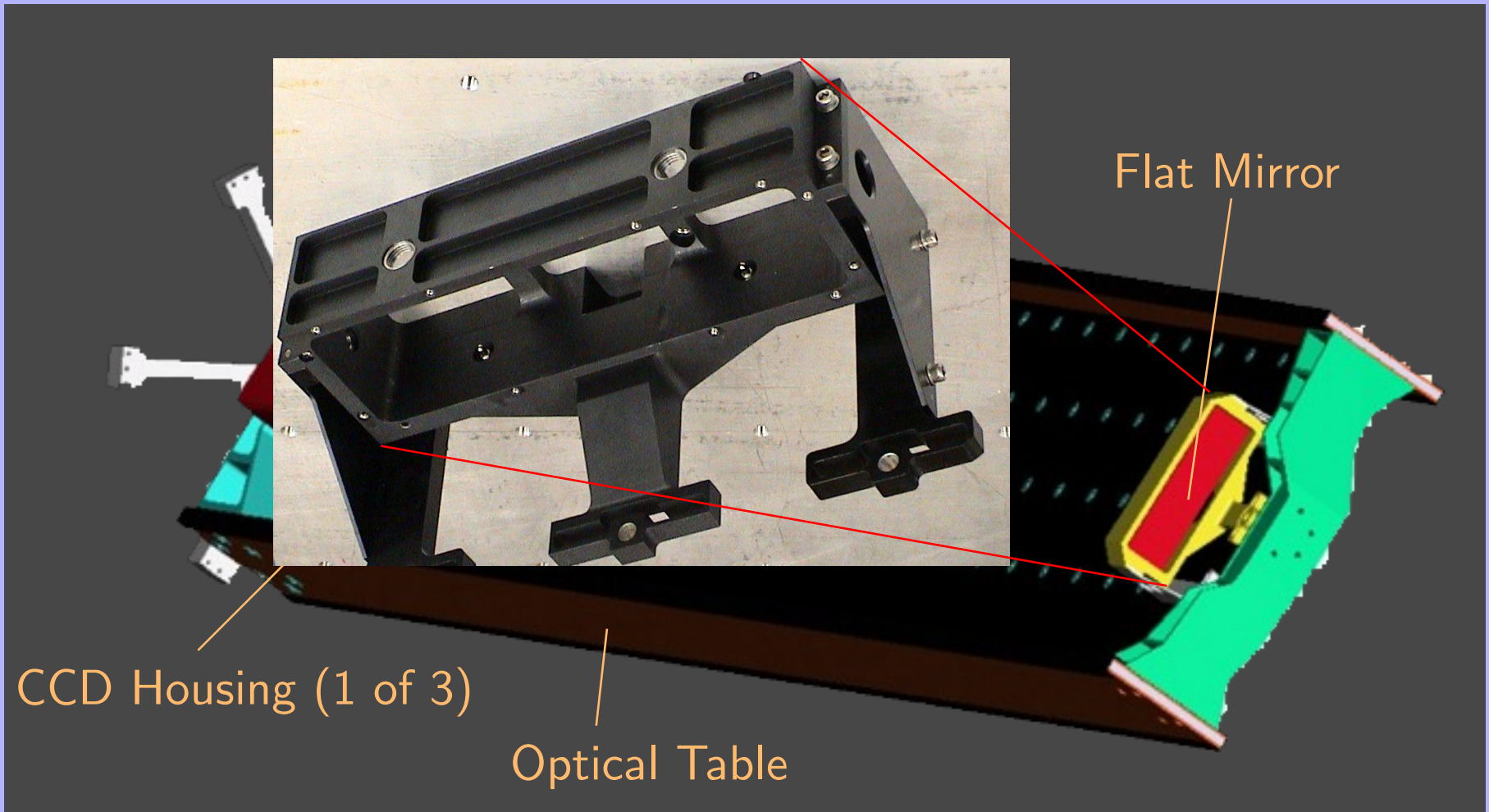

EUV Solar Transition Region

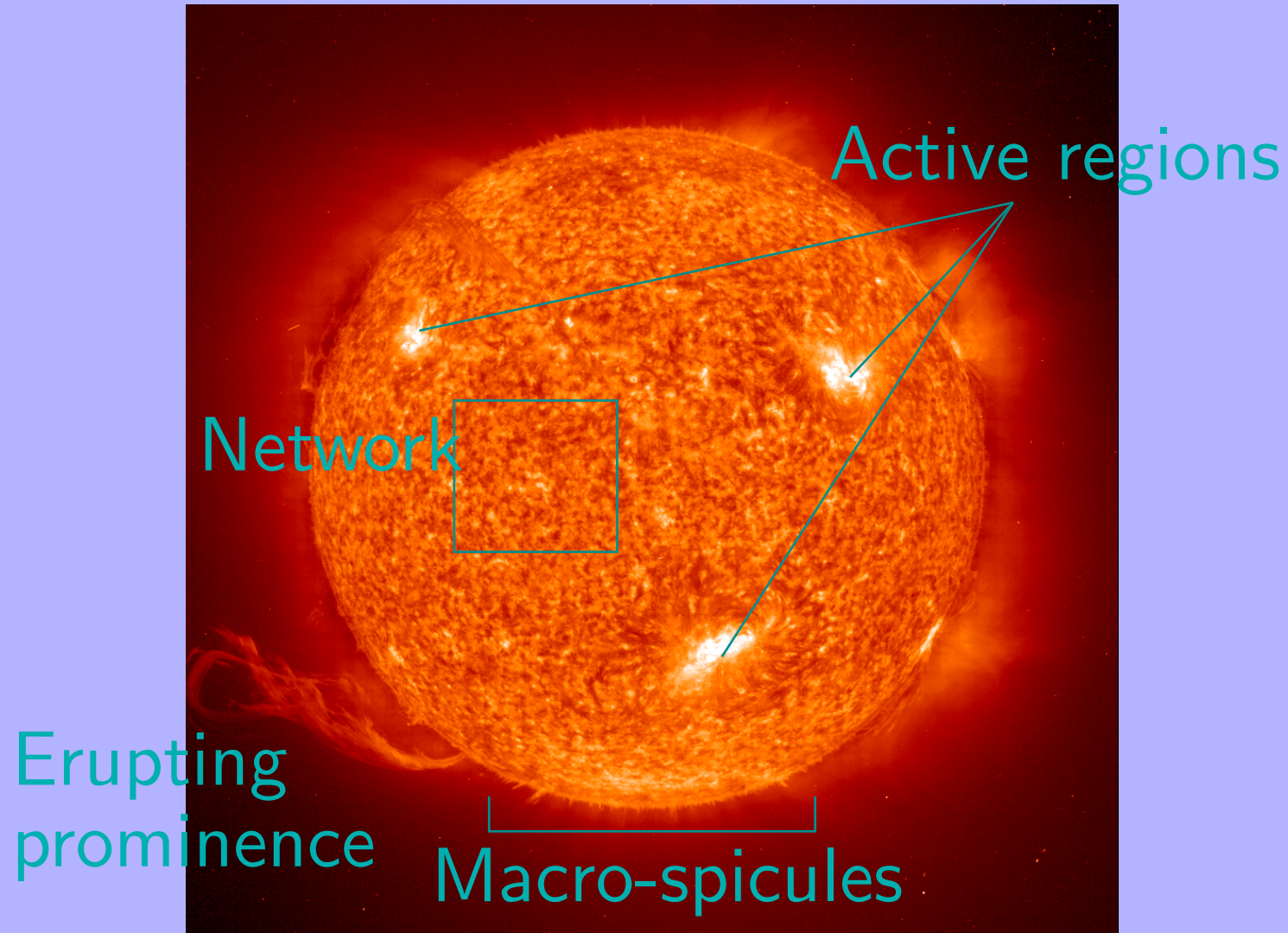

The Sun in He II, $\sim 80,000^{\circ}\text{K}$

Example: Flare Observation

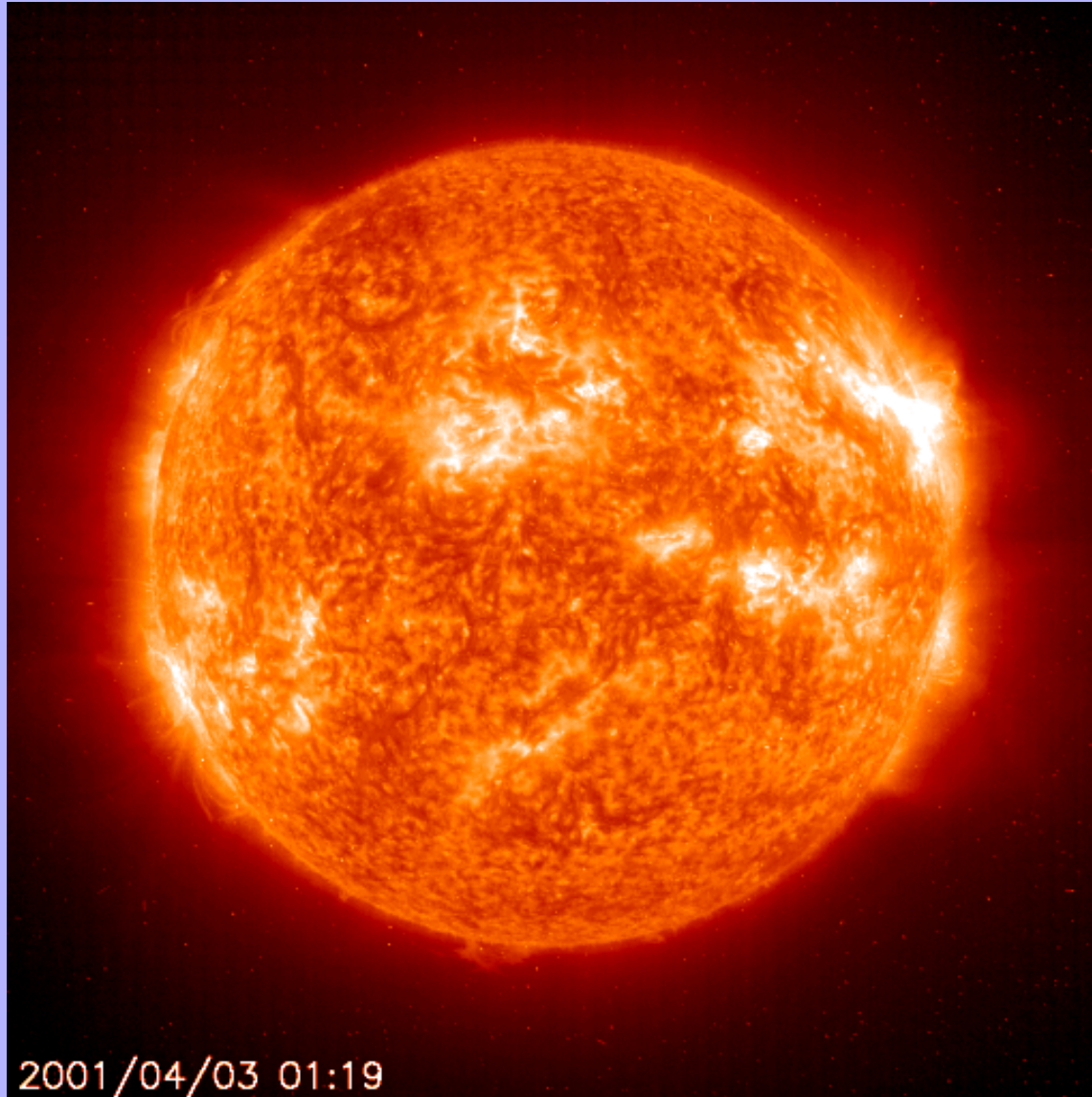

Imager or...

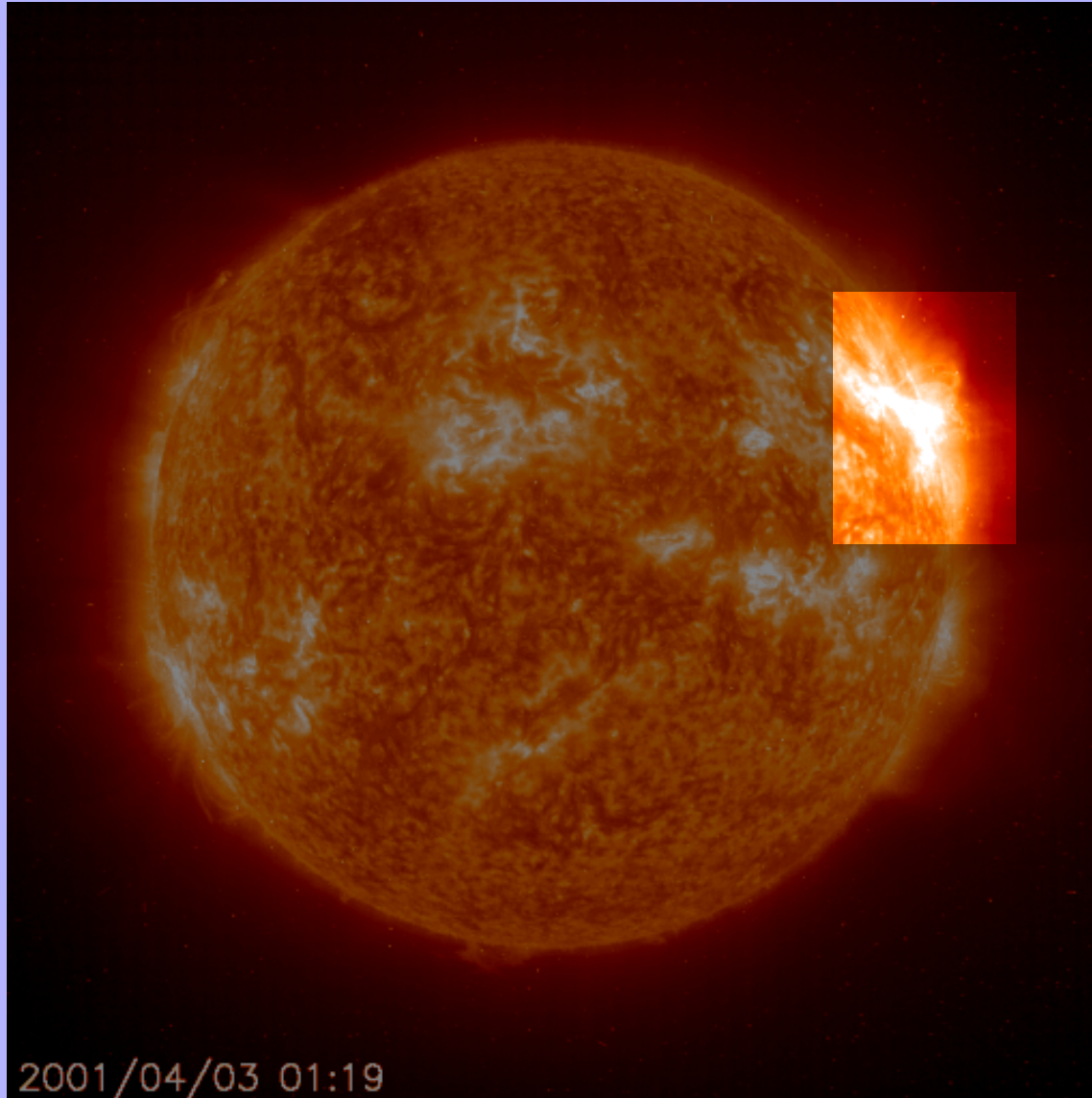

Pretty picture, not very quantitative.

...Spectrometer

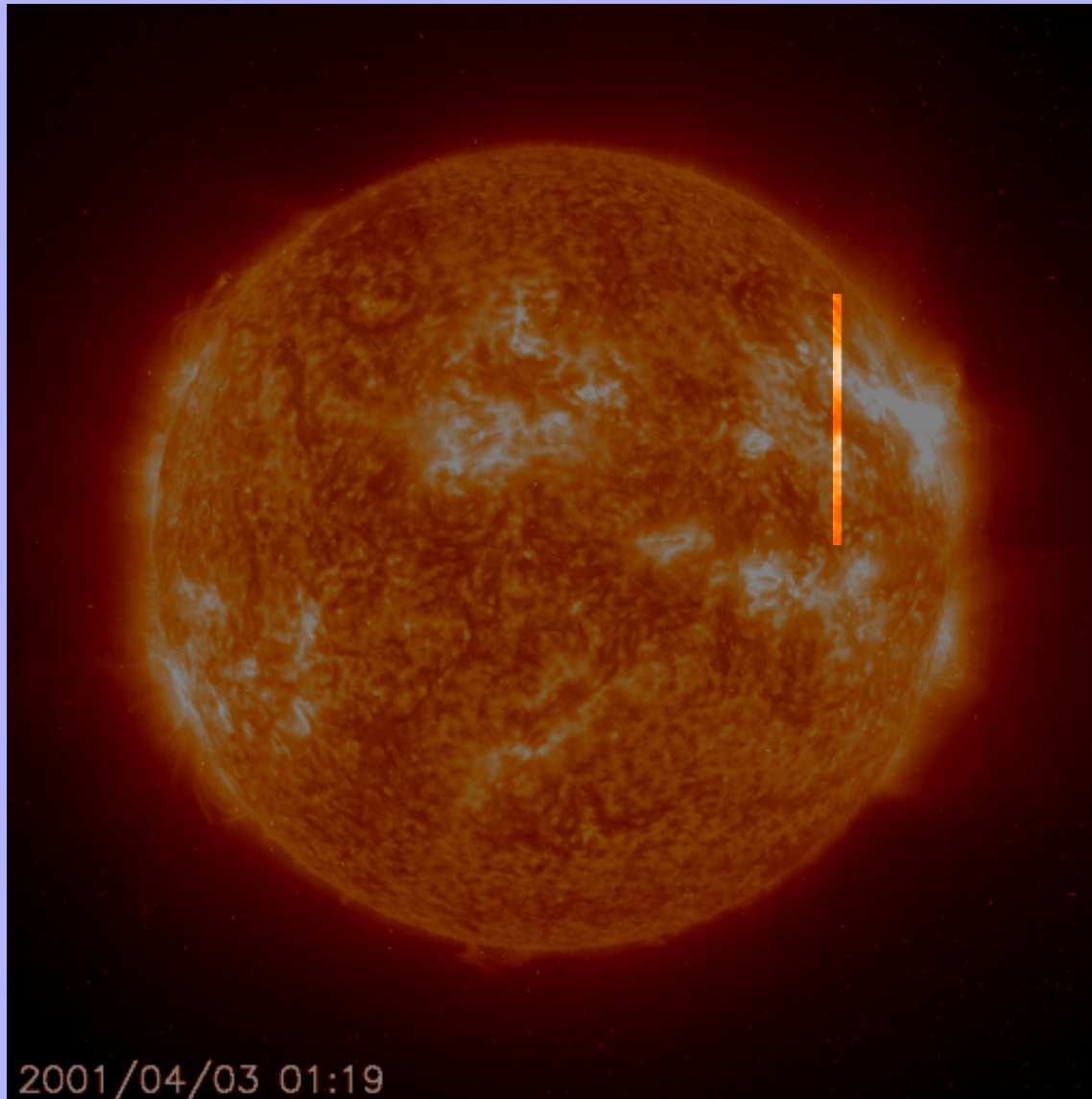

Velocities and temperatures (but only along a slit).

...Spectrometer

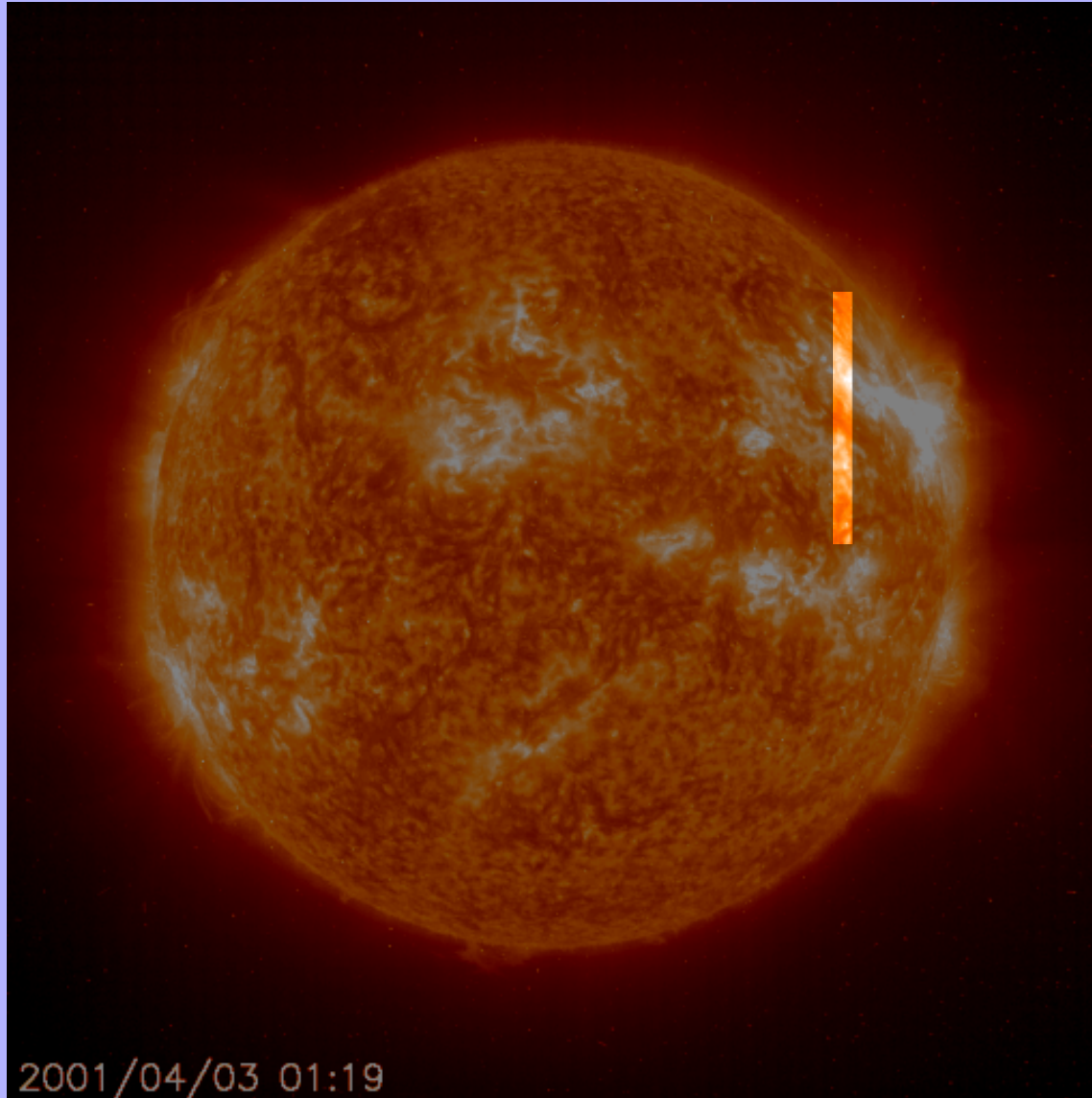

“Rastering” multiple exposures to build an image.

...Spectrometer

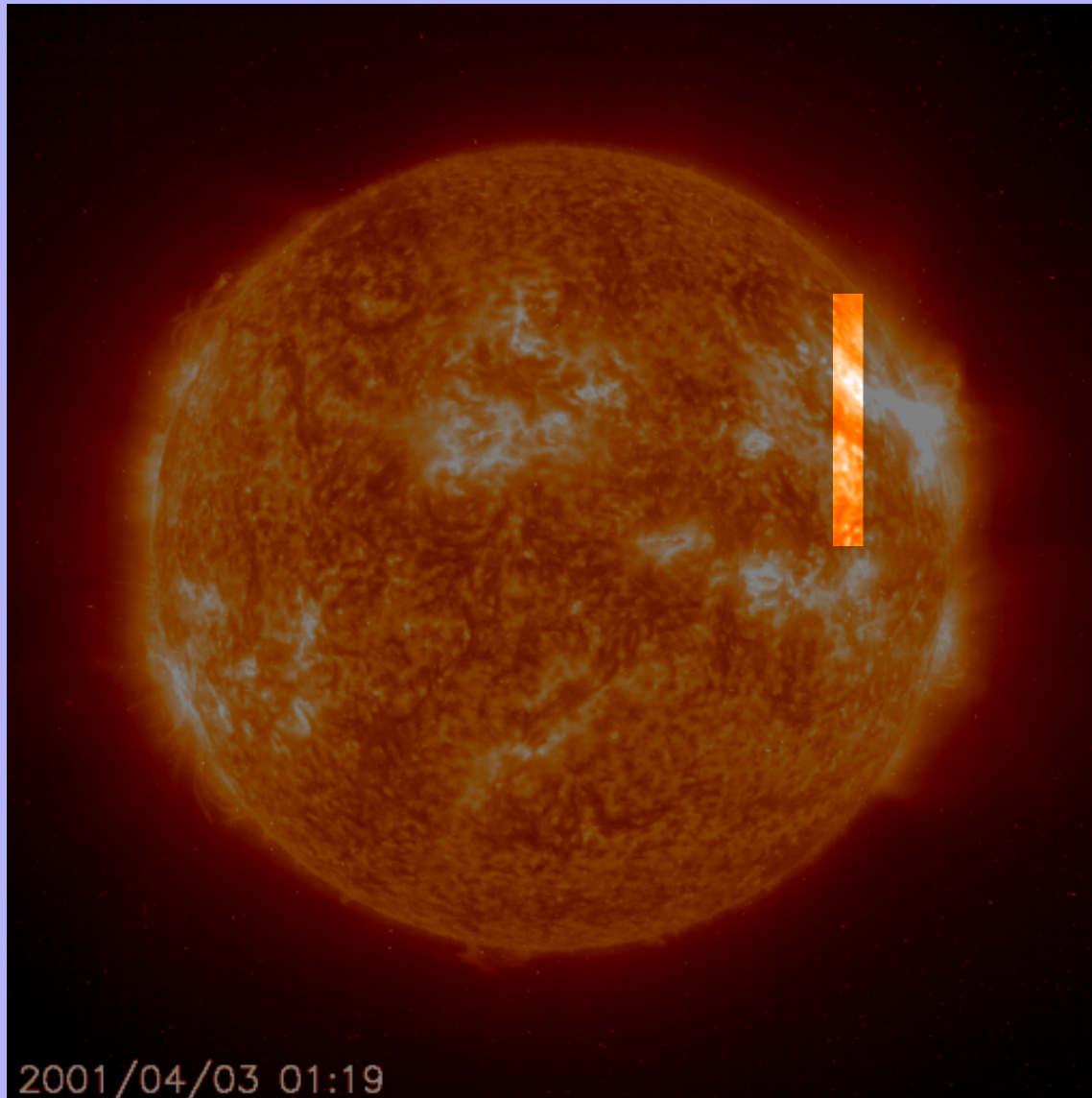

“Rastering” multiple exposures to build an image.

Alternative: *MOSES*

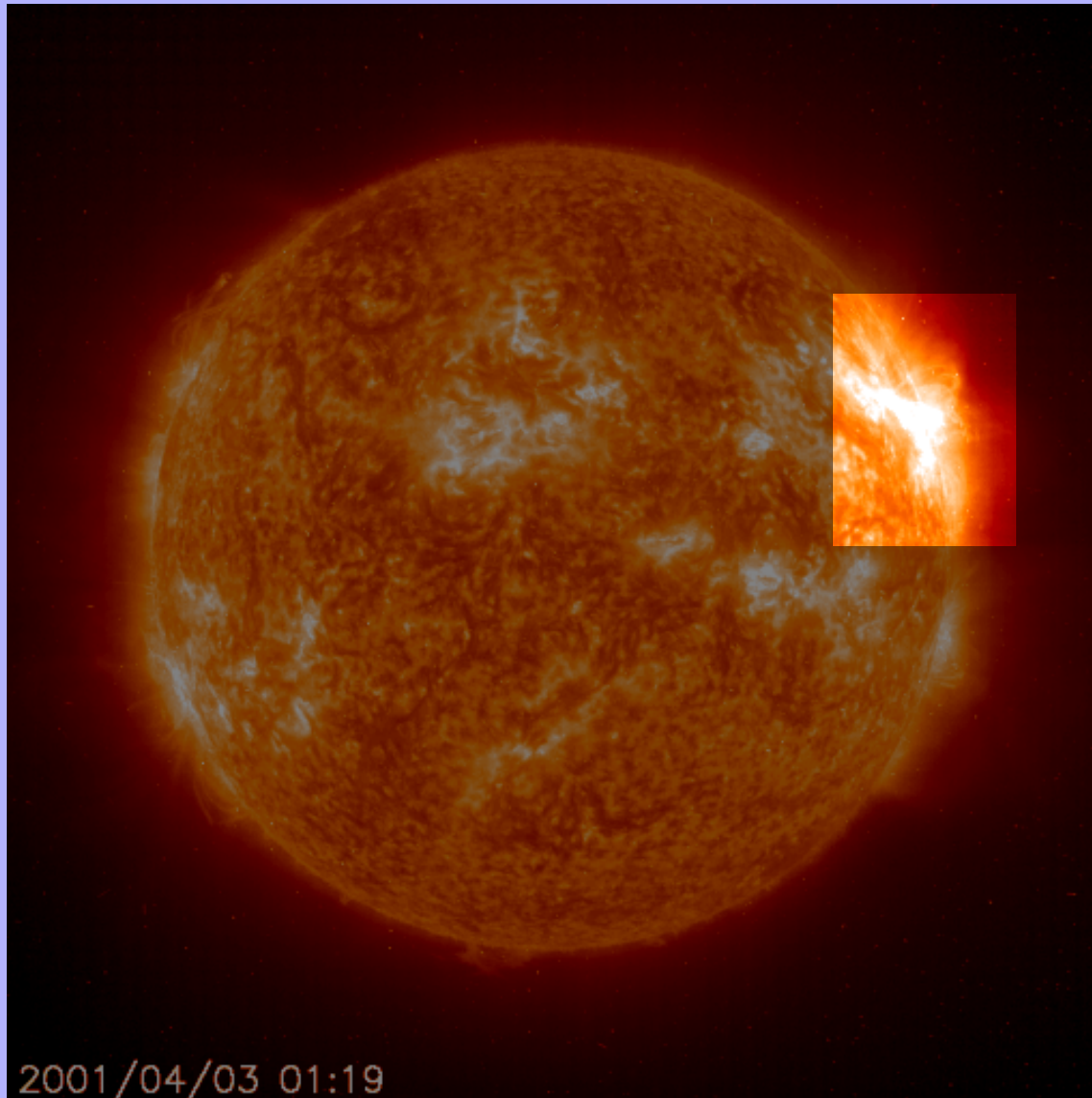

Spectra over entire field in a single exposure!

Multi-order concept

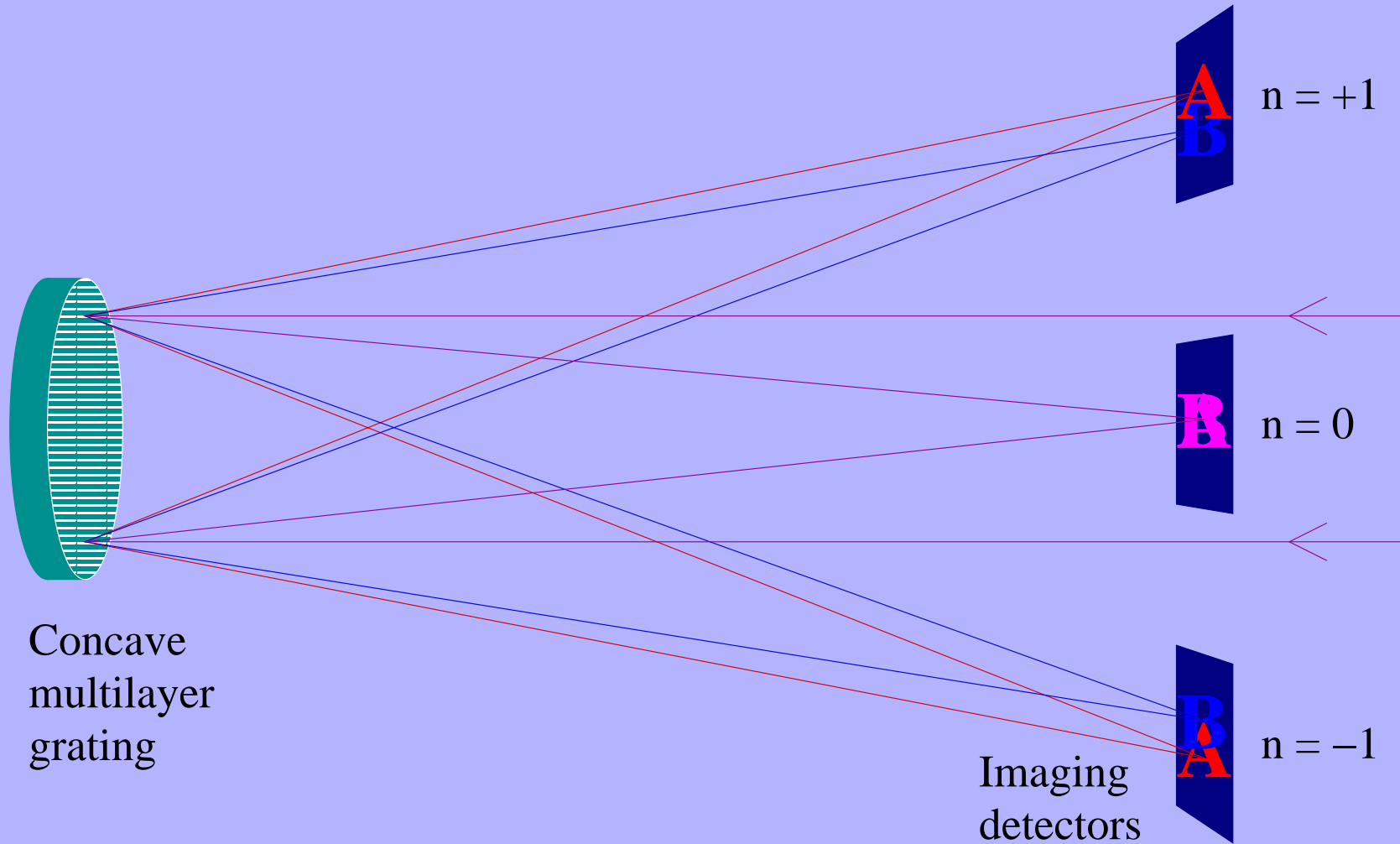

Inversion = Tomography

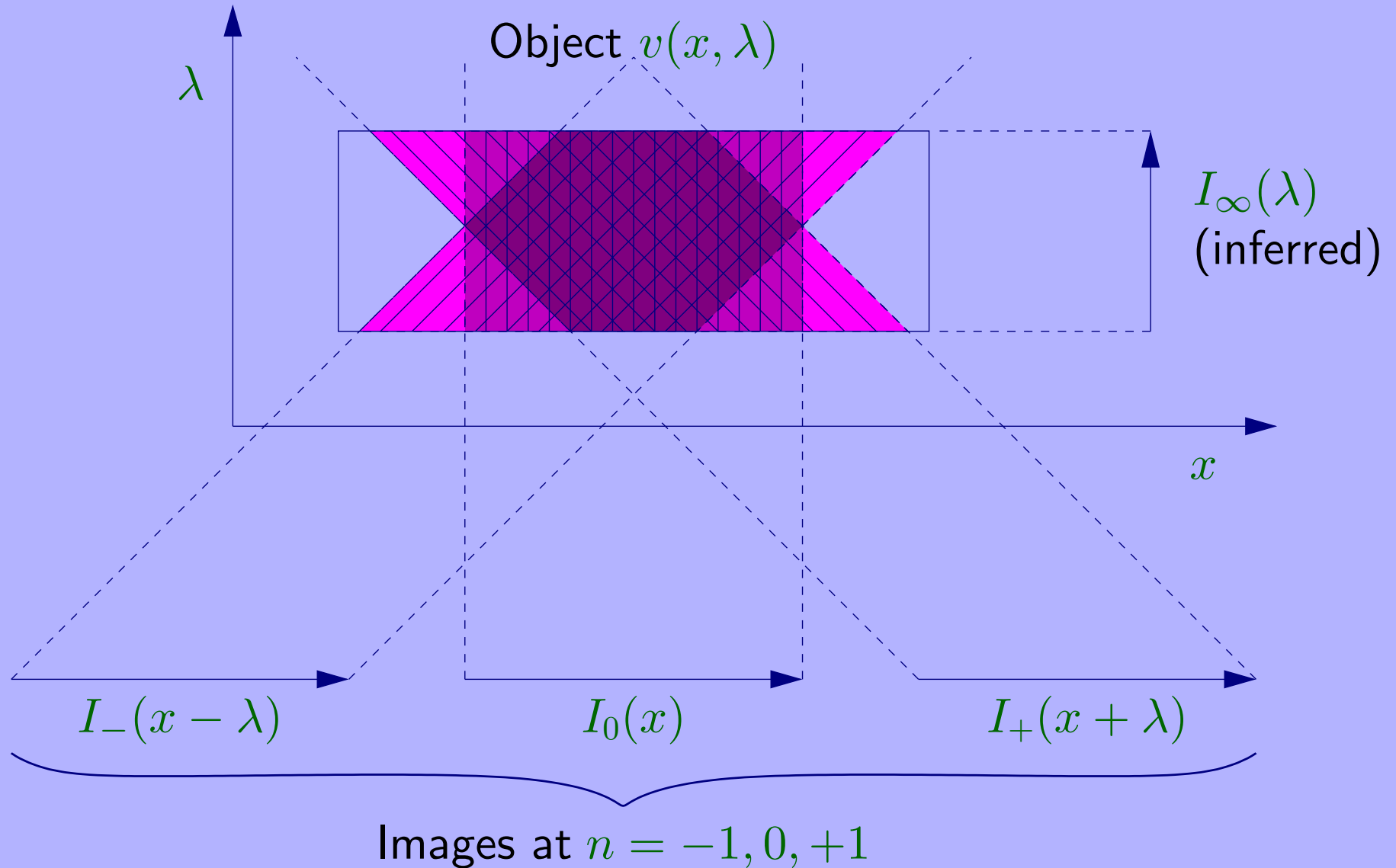



The Big Question: Inversion



Disentangling spatial and spectral information

Can we turn the four projections $I_+(x + \lambda)$, $I_0(x)$, $I_-(x - \lambda)$ and $I_\infty(\lambda)$ back into $I(x, \lambda)$? And if so, how?

The inversion problem seems poorly constrained: solve for $M \times N$ parameters from $M \times 4$ pieces of information!



Reconstruction Algorithms



- Parametric modeling
- Singular value decomposition
- Pixon reconstruction
- Fourier backprojection
- Algebraic reconstruction

Fourier backprojection and Algebraic reconstruction will be discussed in detail.

Fourier Slice Theorem

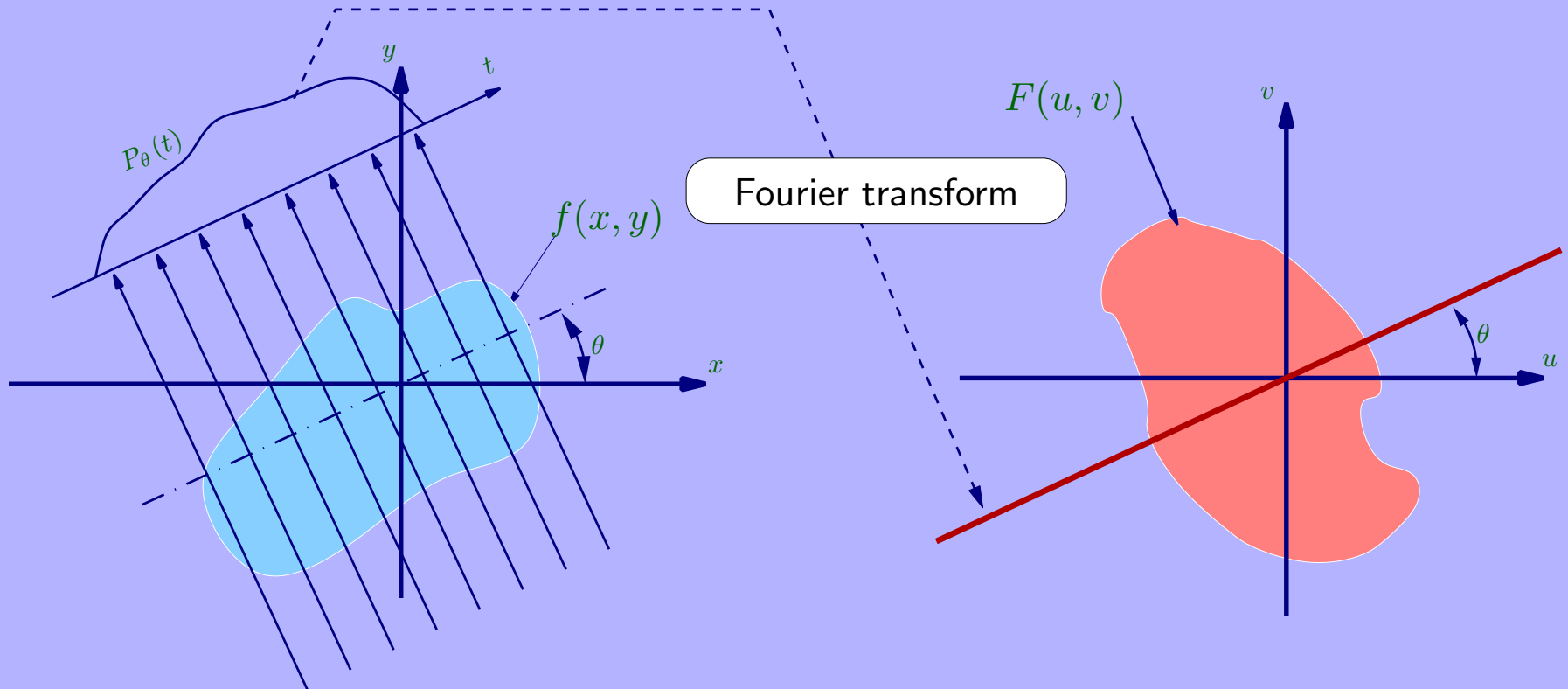



Fourier Backprojection



1.



Fourier Backprojection



1. Create a blank image $F(u, v)$ that will hold the FFT of the reconstructed image $I(x, \lambda)$.



Fourier Backprojection



1. Create a blank image $F(u, v)$ that will hold the FFT of the reconstructed image $I(x, \lambda)$.
2. Take the Fourier Transform $F_n(k)$ of each of the four projections I_+, I_-, I_0, I_∞ .

Fourier Backprojection



1. Create a blank image $F(u, v)$ that will hold the FFT of the reconstructed image $I(x, \lambda)$.
2. Take the Fourier Transform $F_n(k)$ of each of the four projections I_+, I_-, I_0, I_∞ .
3. Use the F_n to fill in the appropriate slices of $F(u, v)$.

Fourier Backprojection



1. Create a blank image $F(u, v)$ that will hold the FFT of the reconstructed image $I(x, \lambda)$.
2. Take the Fourier Transform $F_n(k)$ of each of the four projections I_+, I_-, I_0, I_∞ .
3. Use the F_n to fill in the appropriate slices of $F(u, v)$.
4. Apply the inverse transform to obtain an initial guess $I(x, \lambda)$.



Iterating for non-negativity



Problem: negative counts in the backprojected image.

1.



Iterating for non-negativity



Problem: negative counts in the backprojected image.

1. Zero all negative elements of the backprojection.



Iterating for non-negativity



Problem: negative counts in the backprojected image.

1. Zero all negative elements of the backprojection.
2. Fourier transform the result, use it to fill the wedges of $F(u, v)$ that are not constrained by the data.



Iterating for non-negativity



Problem: negative counts in the backprojected image.

1. Zero all negative elements of the backprojection.
2. Fourier transform the result, use it to fill the wedges of $F(u, v)$ that are not constrained by the data.
3. Inverse Fourier transform to obtain an improved backprojection.



Iterating for non-negativity



Problem: negative counts in the backprojected image.

1. Zero all negative elements of the backprojection.
2. Fourier transform the result, use it to fill the wedges of $F(u, v)$ that are not constrained by the data.
3. Inverse Fourier transform to obtain an improved backprojection.
4. Repeat until the sum of the negative counts in the backprojection is small compared to the total uncertainty in image counts.



Iterating for non-negativity



Problem: negative counts in the backprojected image.

1. Zero all negative elements of the backprojection.
2. Fourier transform the result, use it to fill the wedges of $F(u, v)$ that are not constrained by the data.
3. Inverse Fourier transform to obtain an improved backprojection.
4. Repeat until the sum of the negative counts in the backprojection is small compared to the total uncertainty in image counts.
5. Zero all negative pixels in the backprojection.

Backprojection Example

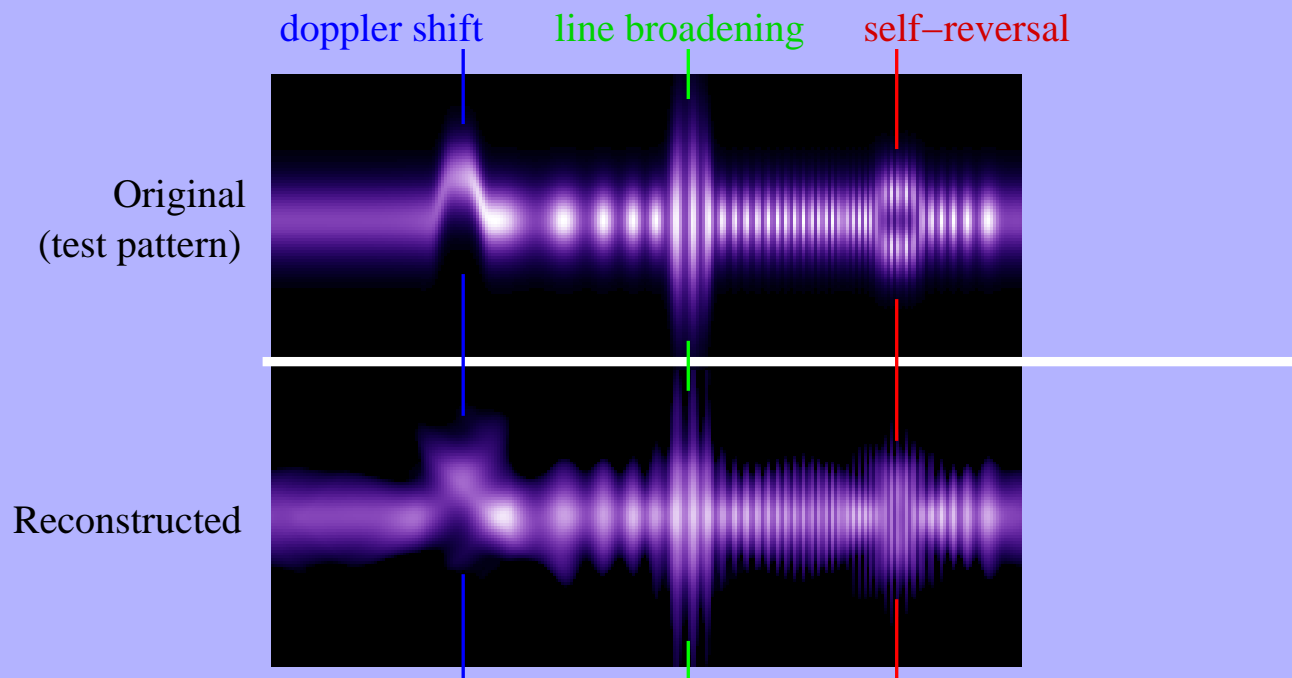

A test pattern is projected onto the three spectrograph orders and then reconstructed by Fourier backprojection with two added constraints: (1) the slit averaged spectrum and (2) non-negativity. The doppler shift and line width are preserved but the self-reversal is suppressed.



Smooth Multiplicative Algebraic Reconstruction Technique



1.



Smooth Multiplicative Algebraic Reconstruction Technique

1. $G(x, \lambda) = I_0(x) I_\infty(\lambda) / N$ Initial guess.



Smooth Multiplicative Algebraic Reconstruction Technique

1. $G(x, \lambda) = I_0(x) I_\infty(\lambda) / N$ Initial guess.
2. $[I'_0, I'_+, I'_-, I'_\infty] = T G$ Projection.



Smooth Multiplicative



Algebraic Reconstruction Technique

1. $G(x, \lambda) = I_0(x) I_\infty(\lambda) / N$ Initial guess.
2. $[I'_0, I'_+, I'_-, I'_\infty] = T G$ Projection.
3. $G = G \left[\frac{I_0(x)}{I'_0(x)} \right]^\gamma \cdot \left[\frac{I_+(x+\lambda)}{I'_+(x+\lambda)} \right]^\gamma \cdot \left[\frac{I_-(x-\lambda)}{I'_-(x-\lambda)} \right]^\gamma \cdot \left[\frac{I_\infty(\lambda)}{I'_\infty(\lambda)} \right]^\gamma$ Correction.

Smooth Multiplicative Algebraic Reconstruction Technique

1. $G(x, \lambda) = I_0(x) I_\infty(\lambda) / N$ Initial guess.
2. $[I'_0, I'_+, I'_-, I'_\infty] = T G$ Projection.
3. $G = G \left[\frac{I_0(x)}{I'_0(x)} \right]^\gamma \cdot \left[\frac{I_+(x+\lambda)}{I'_+(x+\lambda)} \right]^\gamma \cdot \left[\frac{I_-(x-\lambda)}{I'_-(x-\lambda)} \right]^\gamma \cdot \left[\frac{I_\infty(\lambda)}{I'_\infty(\lambda)} \right]^\gamma$ Correction.
4. $G = G \otimes \frac{1}{1+2a+2b} \begin{bmatrix} 0 & a & 0 \\ b & 1 & b \\ 0 & a & 0 \end{bmatrix}$ Smoothing.

Smooth Multiplicative Algebraic Reconstruction Technique

1. $G(x, \lambda) = I_0(x) I_\infty(\lambda) / N$ Initial guess.
2. $[I'_0, I'_+, I'_-, I'_\infty] = T G$ Projection.
3. $G = G \left[\frac{I_0(x)}{I'_0(x)} \right]^\gamma \cdot \left[\frac{I_+(x+\lambda)}{I'_+(x+\lambda)} \right]^\gamma \cdot \left[\frac{I_-(x-\lambda)}{I'_-(x-\lambda)} \right]^\gamma \cdot \left[\frac{I_\infty(\lambda)}{I'_\infty(\lambda)} \right]^\gamma$ Correction.
4. $G = G \otimes \frac{1}{1+2a+2b} \begin{bmatrix} 0 & a & 0 \\ b & 1 & b \\ 0 & a & 0 \end{bmatrix}$ Smoothing.
5. $[I'_0, I'_+, I'_-, I'_\infty] = T G$ Projection.

Smooth Multiplicative Algebraic Reconstruction Technique

1. $G(x, \lambda) = I_0(x) I_\infty(\lambda) / N$ Initial guess.
2. $[I'_0, I'_+, I'_-, I'_\infty] = T G$ Projection.
3. $G = G \left[\frac{I_0(x)}{I'_0(x)} \right]^\gamma \cdot \left[\frac{I_+(x+\lambda)}{I'_+(x+\lambda)} \right]^\gamma \cdot \left[\frac{I_-(x-\lambda)}{I'_-(x-\lambda)} \right]^\gamma \cdot \left[\frac{I_\infty(\lambda)}{I'_\infty(\lambda)} \right]^\gamma$ Correction.
4. $G = G \otimes \frac{1}{1+2a+2b} \begin{bmatrix} 0 & a & 0 \\ b & 1 & b \\ 0 & a & 0 \end{bmatrix}$ Smoothing.
5. $[I'_0, I'_+, I'_-, I'_\infty] = T G$ Projection.
6. Evaluate goodness of fit, $\chi_0^2, \chi_+^2, \chi_-^2$.

Smooth Multiplicative Algebraic Reconstruction Technique

1. $G(x, \lambda) = I_0(x) I_\infty(\lambda) / N$ Initial guess.
2. $[I'_0, I'_+, I'_-, I'_\infty] = T G$ Projection.
3. $G = G \left[\frac{I_0(x)}{I'_0(x)} \right]^\gamma \cdot \left[\frac{I_+(x+\lambda)}{I'_+(x+\lambda)} \right]^\gamma \cdot \left[\frac{I_-(x-\lambda)}{I'_-(x-\lambda)} \right]^\gamma \cdot \left[\frac{I_\infty(\lambda)}{I'_\infty(\lambda)} \right]^\gamma$ Correction.
4. $G = G \otimes \frac{1}{1+2a+2b} \begin{bmatrix} 0 & a & 0 \\ b & 1 & b \\ 0 & a & 0 \end{bmatrix}$ Smoothing.
5. $[I'_0, I'_+, I'_-, I'_\infty] = T G$ Projection.
6. Evaluate goodness of fit, $\chi_0^2, \chi_+^2, \chi_-^2$.
7. Adjust smoothing parameters, $a = a / (\chi_+^2 \chi_-^2)$; $b = b / \chi_0^2$.

Smooth Multiplicative Algebraic Reconstruction Technique

1. $G(x, \lambda) = I_0(x) I_\infty(\lambda) / N$ Initial guess.
2. $[I'_0, I'_+, I'_-, I'_\infty] = T G$ Projection.
3. $G = G \left[\frac{I_0(x)}{I'_0(x)} \right]^\gamma \cdot \left[\frac{I_+(x+\lambda)}{I'_+(x+\lambda)} \right]^\gamma \cdot \left[\frac{I_-(x-\lambda)}{I'_-(x-\lambda)} \right]^\gamma \cdot \left[\frac{I_\infty(\lambda)}{I'_\infty(\lambda)} \right]^\gamma$ Correction.
4. $G = G \otimes \frac{1}{1+2a+2b} \begin{bmatrix} 0 & a & 0 \\ b & 1 & b \\ 0 & a & 0 \end{bmatrix}$ Smoothing.
5. $[I'_0, I'_+, I'_-, I'_\infty] = T G$ Projection.
6. Evaluate goodness of fit, $\chi_0^2, \chi_+^2, \chi_-^2$.
7. Adjust smoothing parameters, $a = a / (\chi_+^2 \chi_-^2)$; $b = b / \chi_0^2$.
8. Loop to (3).

SMART example

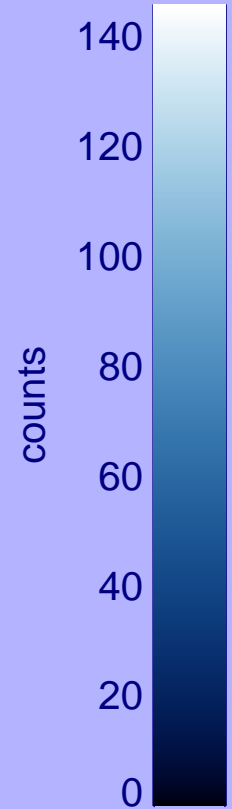
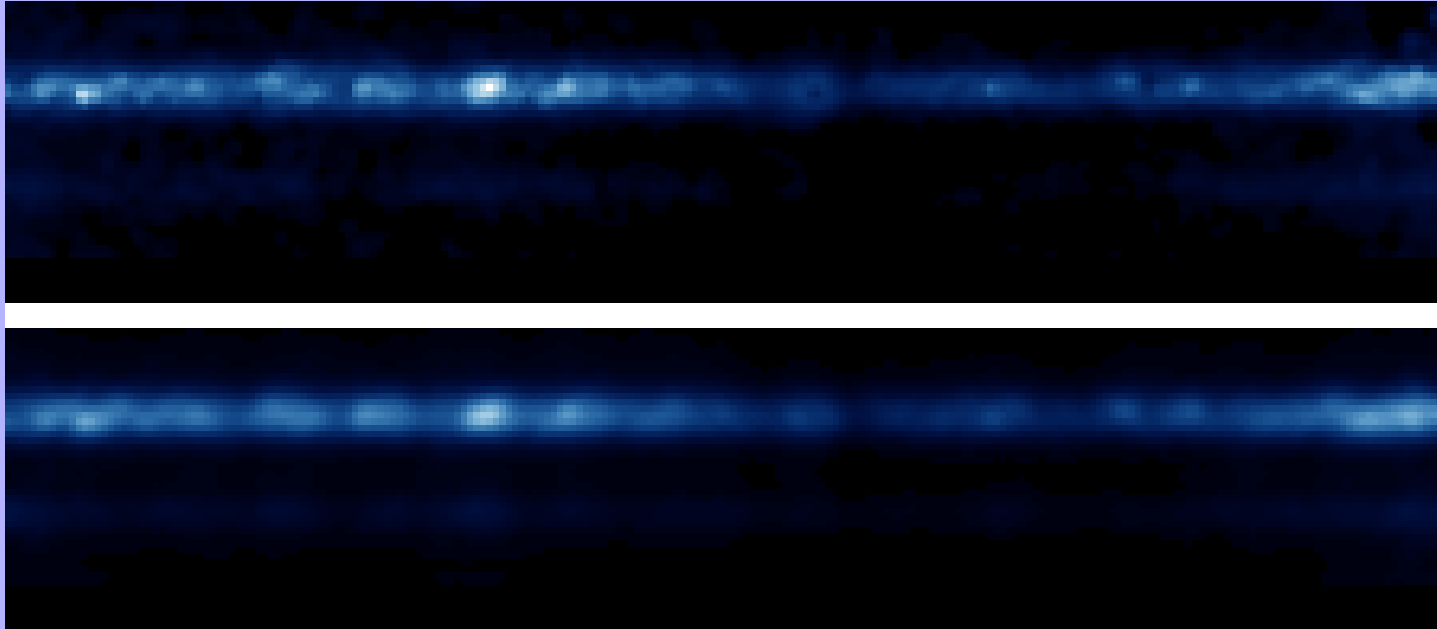



Comparison of Algorithms



Differences between true and reconstructed line profile parameters. Line center and linewidth errors are in pixels. For each parameter, a mean offset and RMS error are given. One *MOSES* pixel is approximately 20 mÅ (20 km/s at 304 Å).

Algorithm	center (median)		width (quartiles 1-3)	
	mean	RMS	mean	RMS
Fourier	-0.01	0.32	-0.19	0.97
SMART	0.04	0.23	0.18	0.34

Doppler Shift Estimation

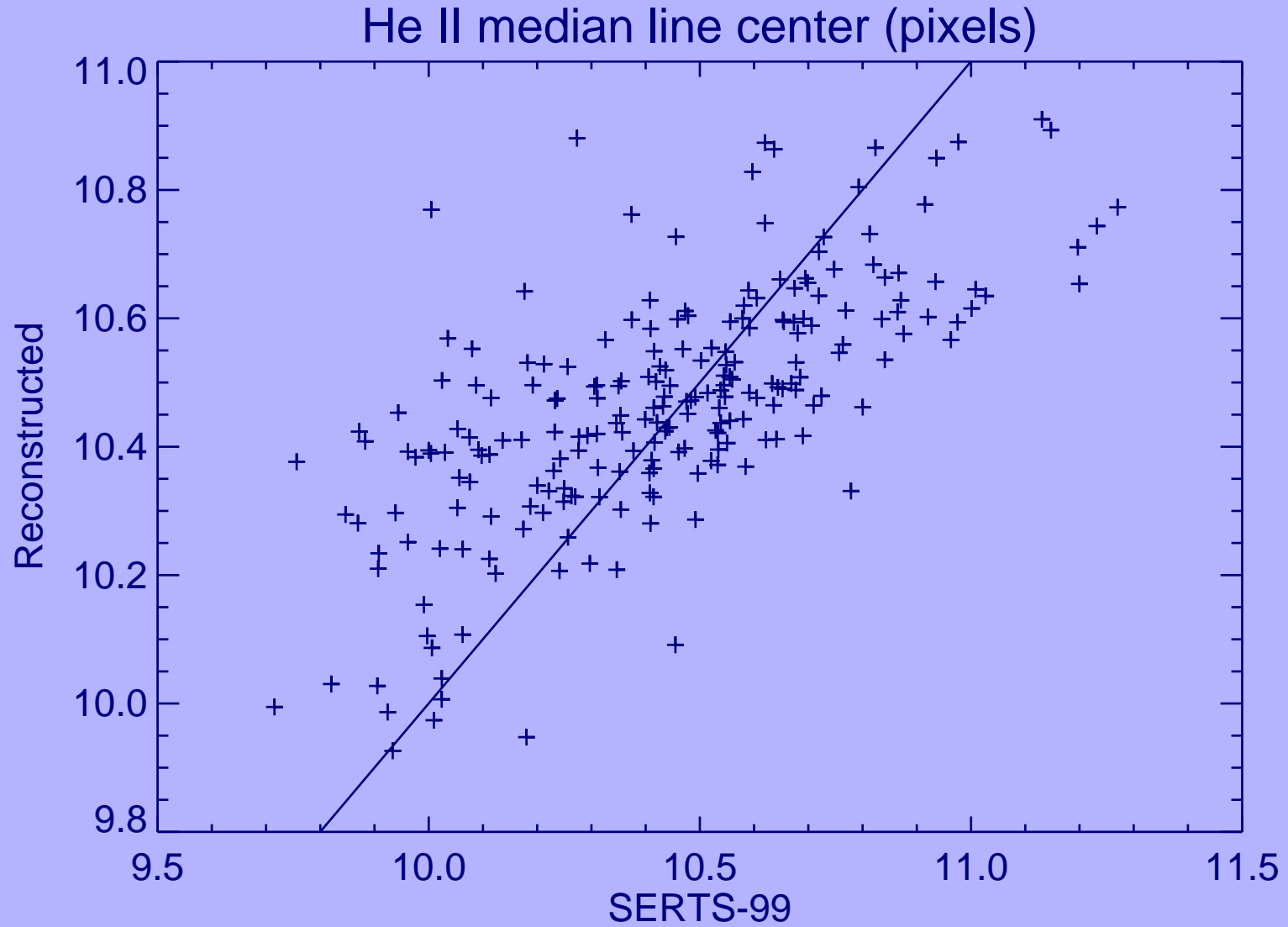



Acknowledgments



The *MOSES* rocket project is sponsored by NASA grant NAG5-10997.