



Small Satellite System Development in the Space Science and Engineering Laboratory

*Montana State University, Department of Physics, 2011 Solar Physics REU
August 3, 2011*

Nathan Fite

Advisor: Dr. David Klumpar

Mentors:

Larry Springer, Keith Mashburn, Ehson Mosleh

Overview

- POES 17
- RAMPART CubeSat
- FIREBIRD A/B CubeSats

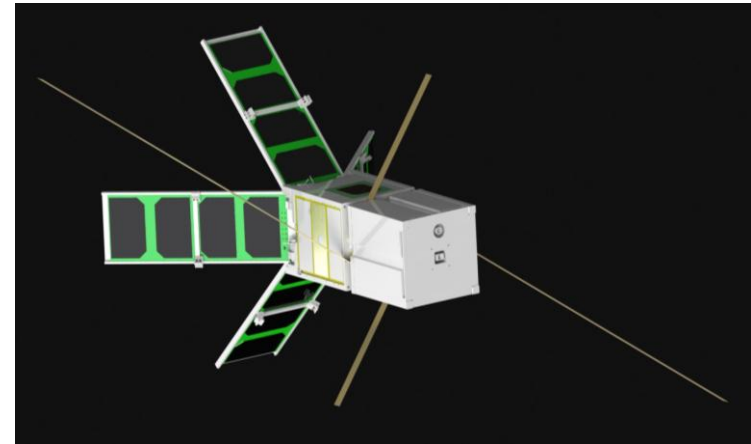

RAMPART



POES 17



FIREBIRD
Mission
Patch

Acronyms and Terminology

- AUT – Antenna Under Test
- BW – Bandwidth
- C&DH – Command and Data Handling
- CDMA – Code Division Multiple Access
- CPW – Coplanar Waveguide
- CTE – Coefficient of Thermal Expansion
- DL - Downlink
- DUT – Device Under Test
- EIRP – Effective Isotropic Radiated Power
- EPS – Electrical Power System
- FSPL – Free Space Path Loss
- G_r – Receive Antenna Gain
- G_t – Transmit Antenna Gain
- GNSS – Guidance and Navigation Satellite System
- GPS – Global Positioning System
- HPBW – Half Power Beam width
- P_a – Power Arriving at Antenna
- PCB – Printed Circuit Board
- PPOD – Poly Picosat Orbital Deployer
- RF – Radio Frequency
- RHCP – Right Hand Circular Polarization
- SDR – Software Defined Radio
- SNA – Scalar Network Analyzer
- SNR – Signal-to-Noise-Ratio
- U – Unit (10cm x 10cm x 10cm)
- UL - Uplink
- VNA – Vector Network Analyzer
- VSWR – Voltage Standing Wave Ratio

POES 17

- Polar-Orbiting Environmental Satellites
- Size: 4m x 2m
- Weight: 2230kg
- NOAA Satellite
- Spin Stabilized
- Similar Data to EIP, built by MSU SSEL
- Template for EIP Data
- Pertinent Data:
 - 4 Telescopes
 - 2 Electron Telescopes of 3 channels each
 - 2 Proton Telescopes of 6 channels each
 - FoLat (Geo-Magnetic Latitude)
 - Pitch Angles (w/ respect to velocity vector)



POES 17

(<http://www.scottchurchdirect.com/global-warming.aspx/troposphere-temperature-trends-pt1>)

POES 17, cont'd

- Proton Telescopes
 - Telescope 1 Oriented Along Velocity Vector
 - Telescope 2 Oriented 90° from Velocity Vector
- 6 Linear, Circular Silicon Chips per Telescope
- Proton Channels Info
 - Channel 1: 30keV to 80keV
 - Channel 2: 80keV to 240keV
 - Channel 3: 240keV to 800 keV
 - Channel 4: 800keV to 2500keV
 - Channel 5: 2500keV to 6900keV
 - Channel 6: $> 6900\text{keV}$

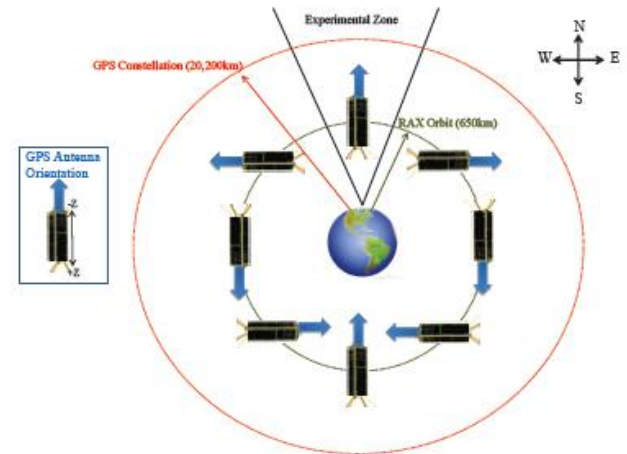

RAX CubeSat
(Courtesy Sara Spangelo,
Michigan University)

Proton Flux vs FoLat

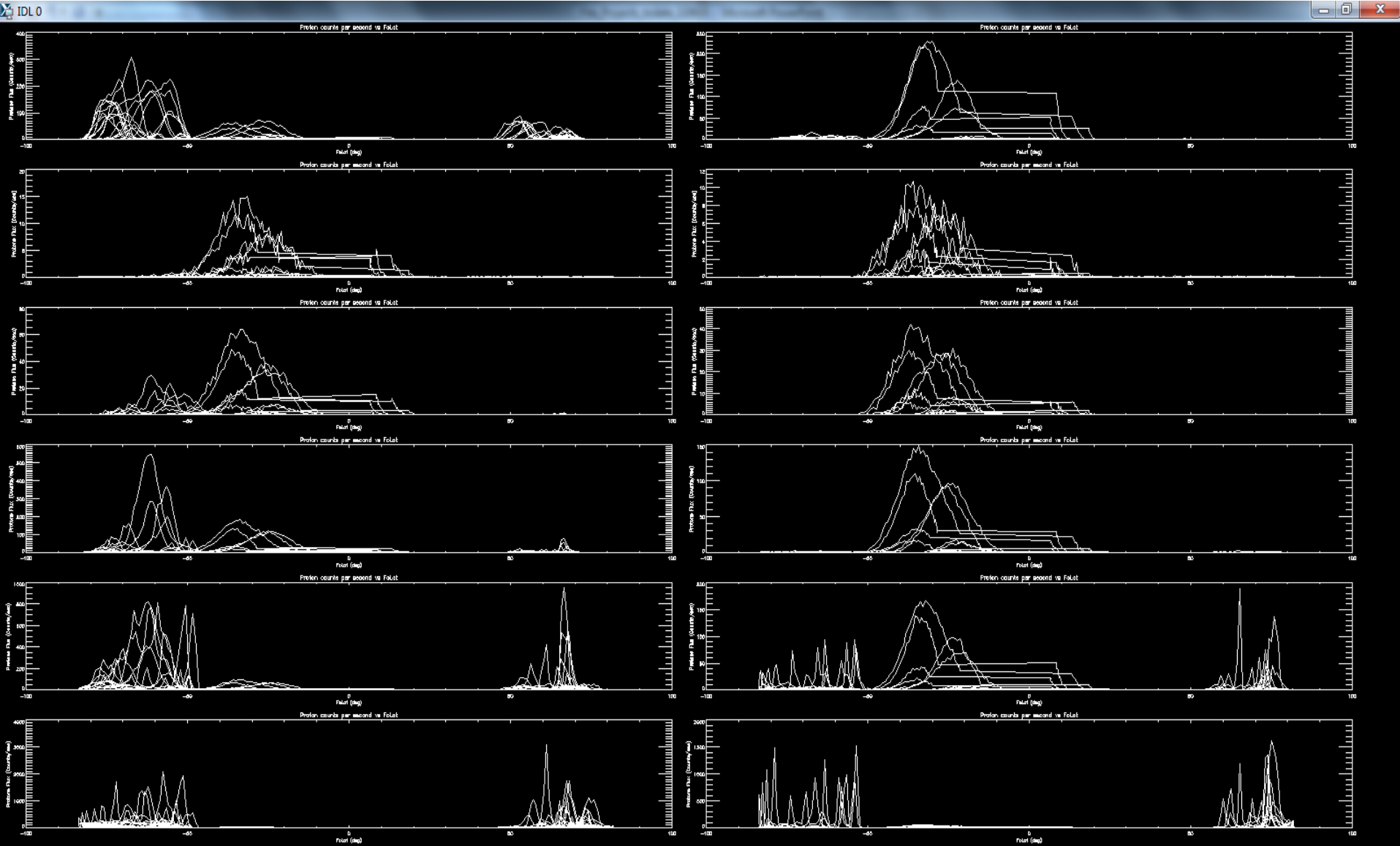

1800 Bins

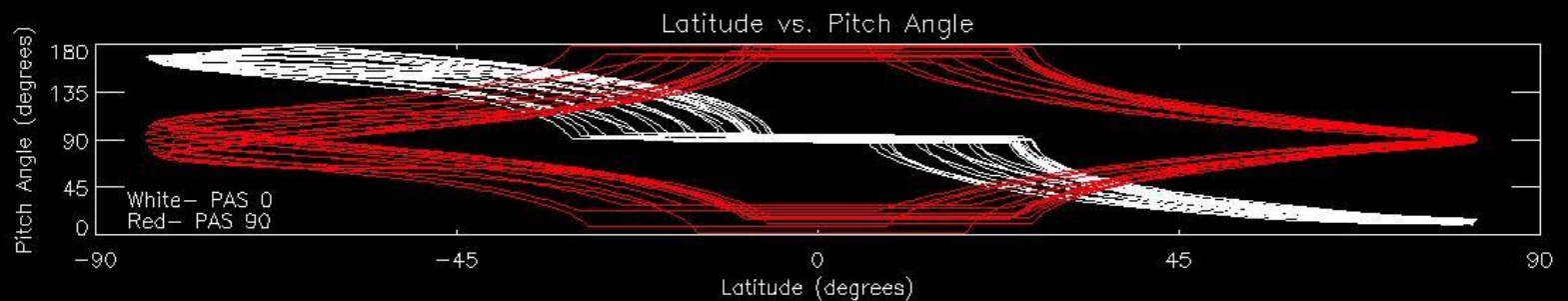
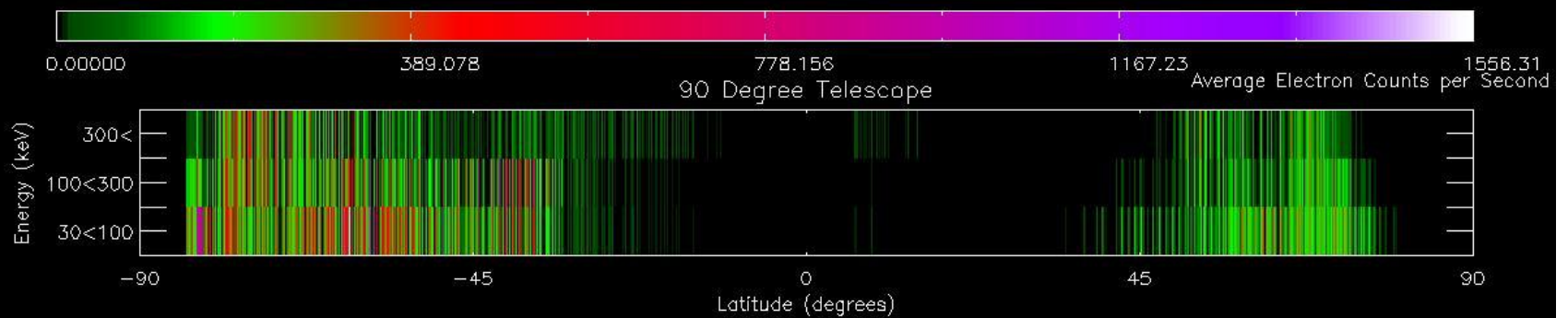
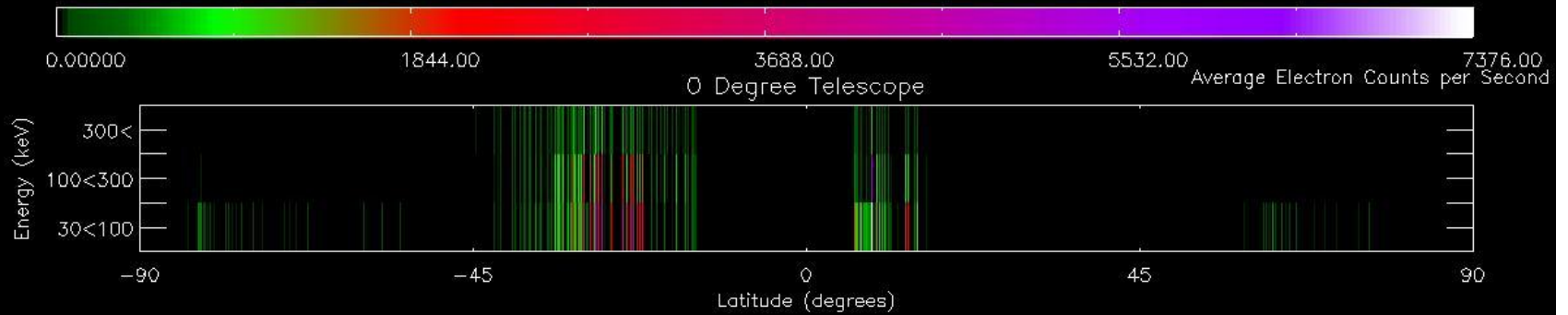

RAMPART

*(Rapid prototyped Microelectromechanical system
and Propulsion and Radiation Test)*

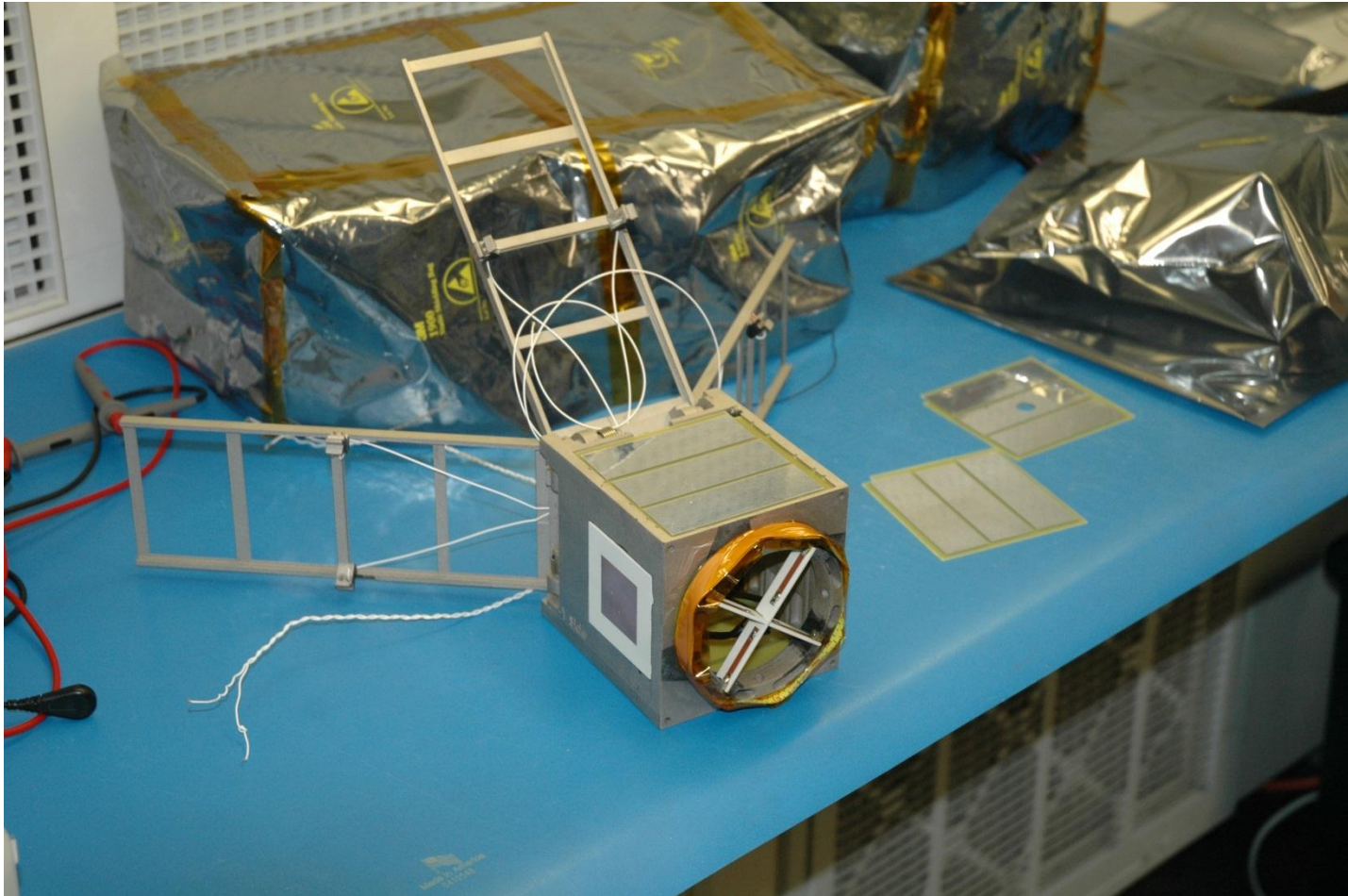

RAMPART Overview

- Project Began 3Q 2009
- Size: 10cm x 10cm x 22cm
- Weight: 3kg
- Work Completed
 - Solar Panels
 - Structure
- Work Completed at MSU
 - Antenna Systems

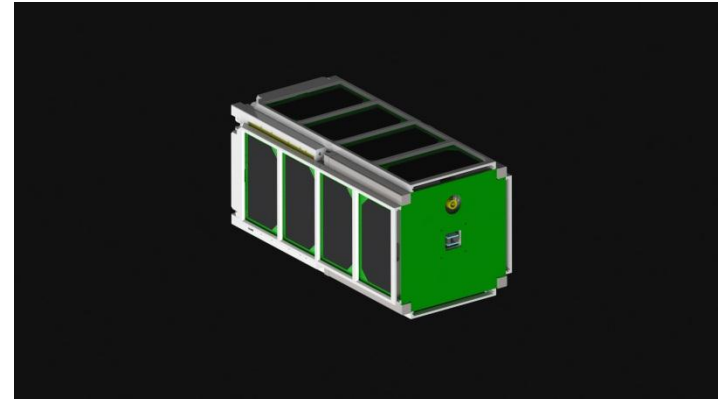

RAMPART Stowed Configuration

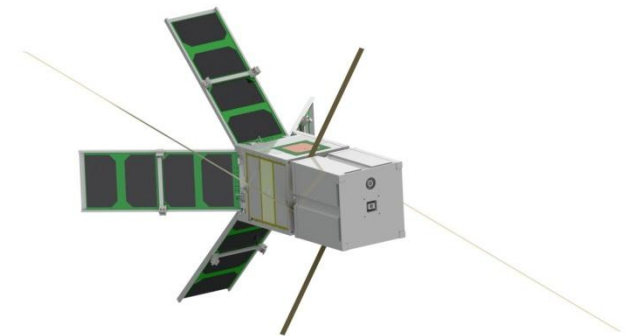

RAMPART Deployed Configuration

Involved Entities

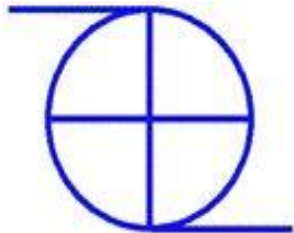

Planetary
Systems
Corporation



WINDFORM[®] LX



Space Dynamics
LABORATORY
Utah State University Research Foundation



RAMPART Mission

- Risk Reduction Mission for POPACS
- Flight Qualify a Payload in low extremities of Van Allen Belts
- Quantify the radiation experienced by payload
- Get to elliptical orbit from 90+ burns from an original LEO circular
- 3D printed Structure

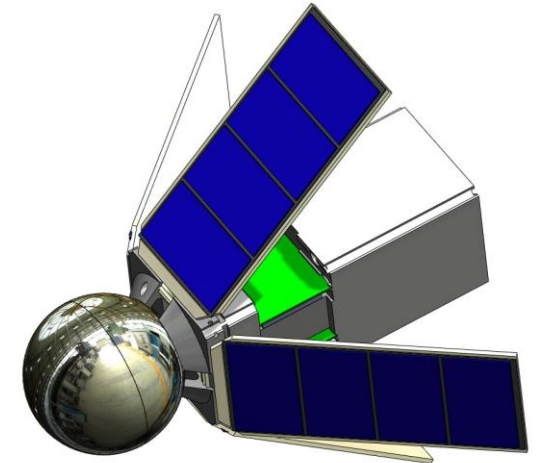

POPACS Configuration

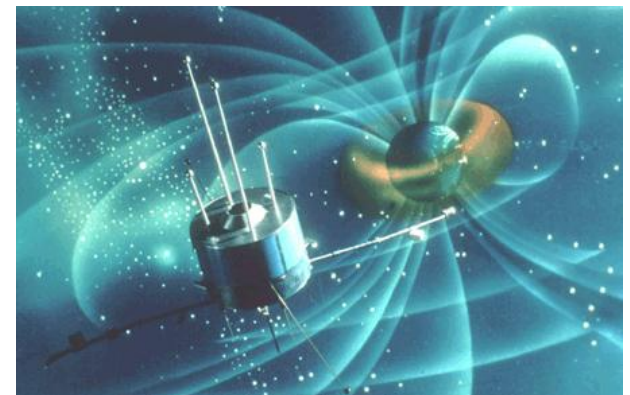

POPACS Mission

- Release 2kg Tungsten Sphere
- Study the Effects of Drag due to Atmospheric Expansion as a function of CMEs
- Same Experiments as RAMPART

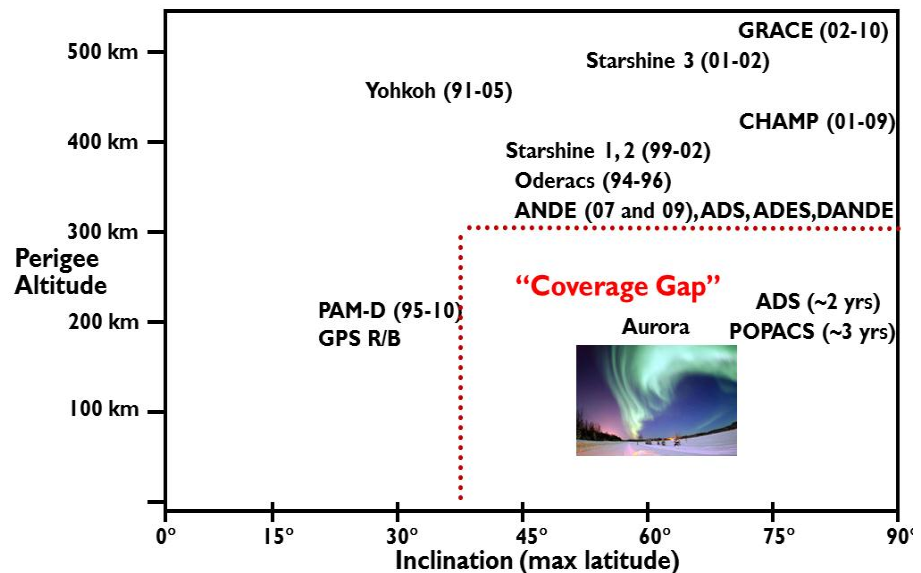
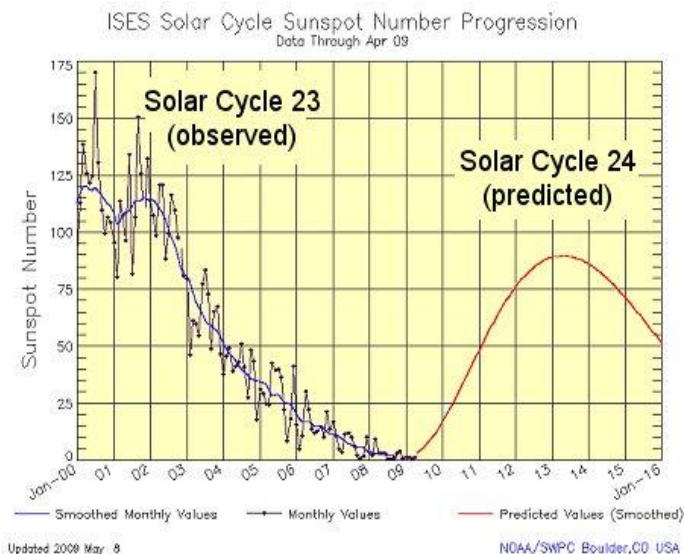

Communications Systems Level Design

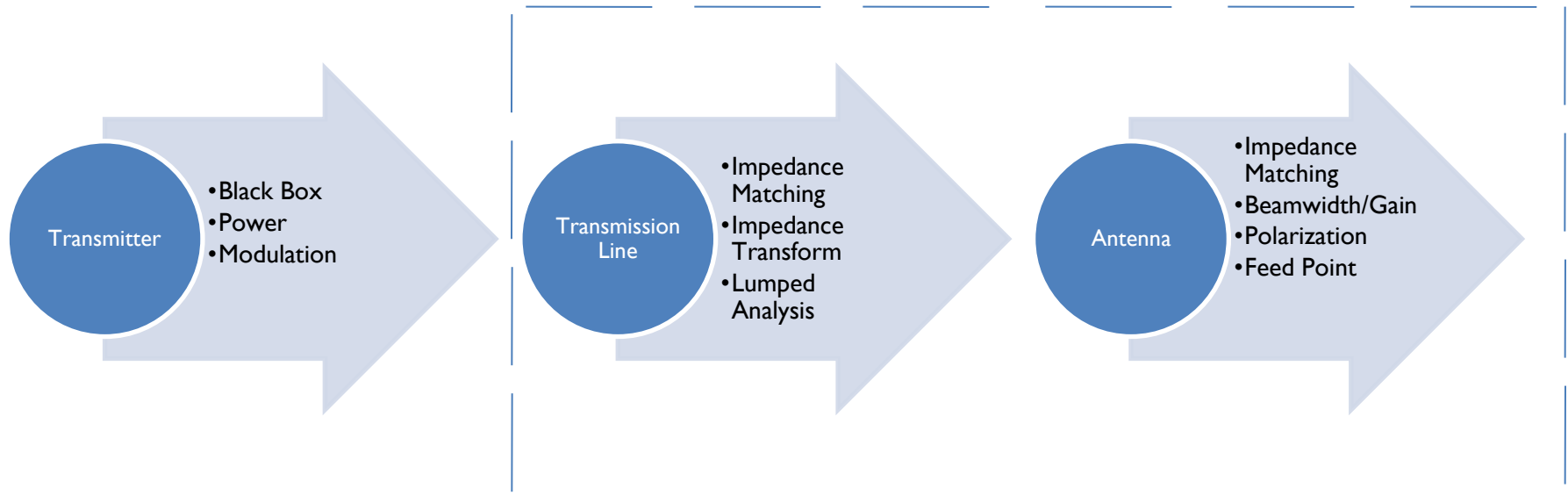

Communications System

- Transmission Lines
 - Impedance: Unmatched cause reflections
 - Can not use simple wire to transport signal
 - Utilize Microstrip
- Antennas
 - Transducers
 - Energy Focusers
 - Used Dipole Antennas

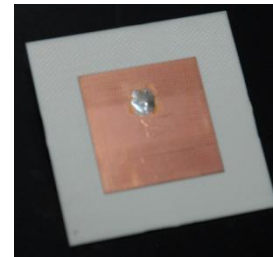
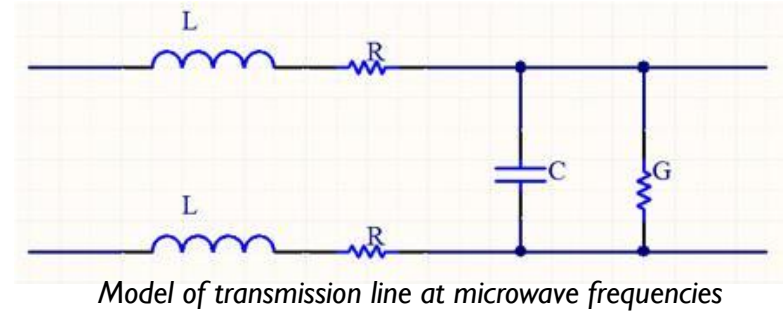

Microstrip Patch Antenna

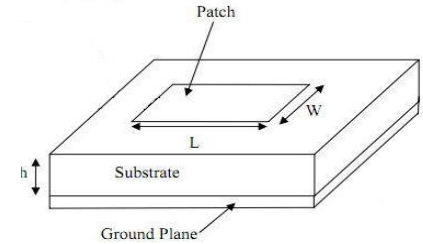

(Nakar,,
2004)

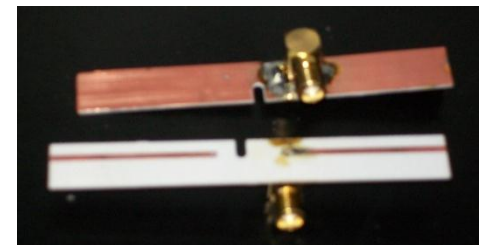

VHF/UHF Transmission Lines

RAMPART Deployment

[RAMPART Deployment Video](#)

FIREBIRD

(Focused Investigations of Relativistic Electron Burst Intensity, Range, and Dynamics)

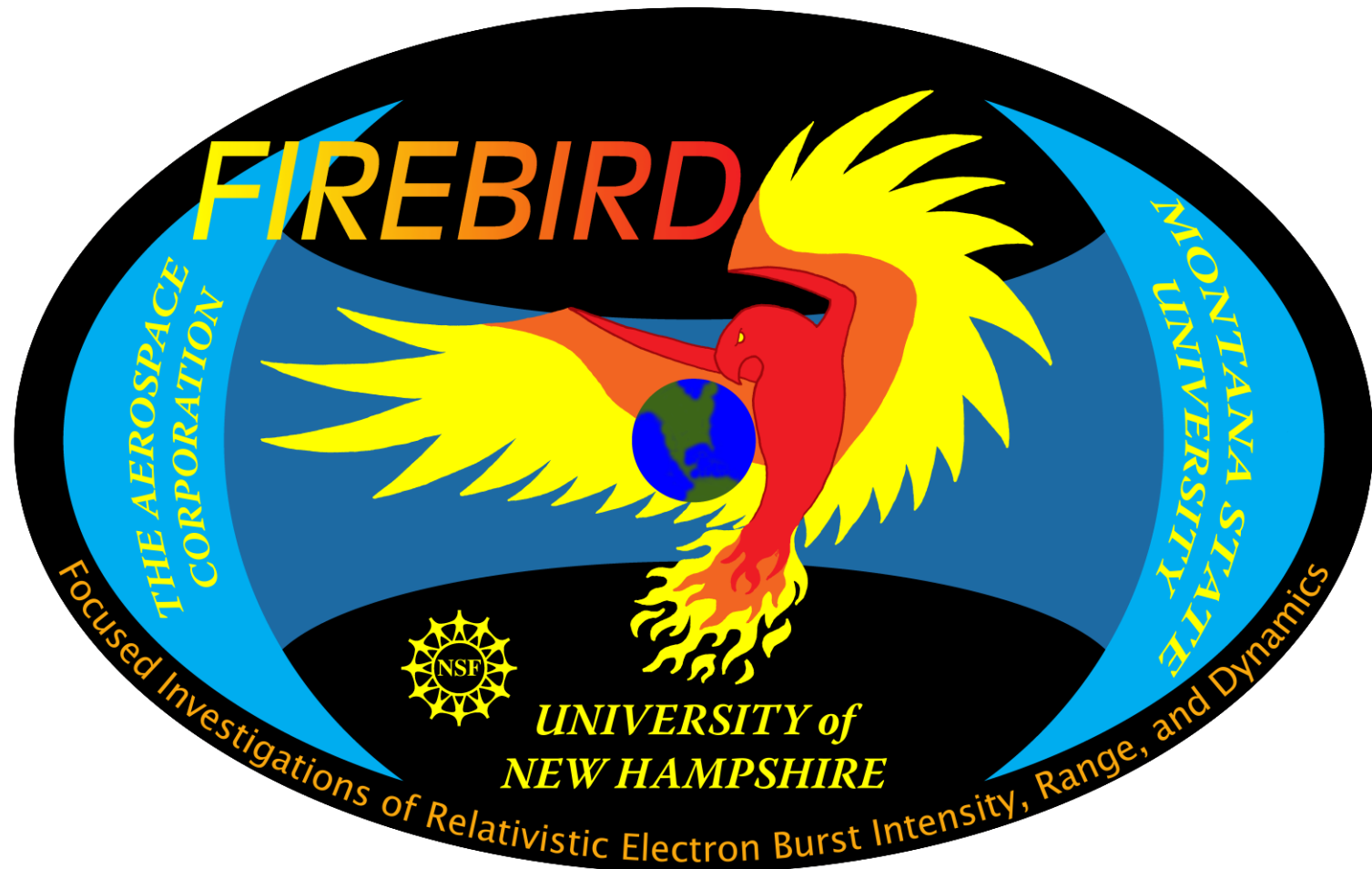

FIREBIRD A/B

- 2 Satellite Constellation
- Size: 10cm x 10cm x 16cm
- Weight: 2kg
- Designed and Built by the MSU SSEL, University of New Hampshire, The Aerospace Corporation
- Microburst Electron Precipitation in Radiation Belt Dynamics
 - What is the spatial scale size of an individual burst?
 - What is the energy dependence of an individual burst?
 - How much total electron loss do bursts produce globally
- Work To-Date
 - FIREBIRD GNSS Unit

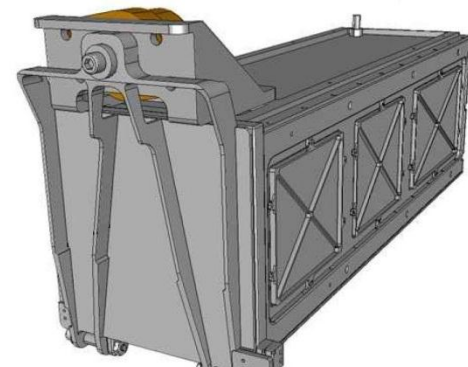

FIREBIRD GNSS

- Utilize GPS to PRECISELY measure location, velocity, and time
- Mission requirements: Location +/- 150m
- FIREBIRDS will be traveling at ~ 7.5km/sec
- Time Discrepancies of 0.1sec = 750m, 5 times greater than mission requirement
- Must be kept lower than 20ms



FIREBIRD GPS Card

GPS Constellation

- GPS Constellation consists of 24 satellites (21 used and 3 backups)
- Height of 20,200km above MSL in 6 orbital planes

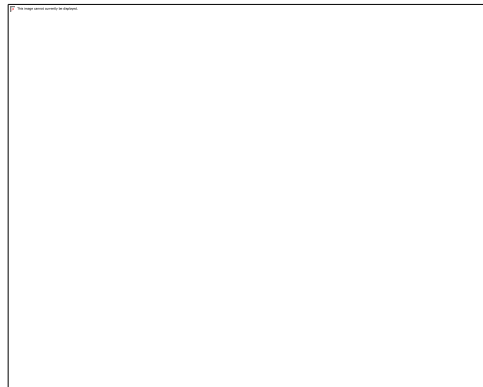

GPS Constellation in
Orbital Planes



Block IIR GPS Satellite

GPS Signal

- Composed of:
 - VERY Accurate GPS Satellite Ephemerides
 - VERY Accurate Rubidium Time Standards
 - GPS Satellite Health Information
 - Error Correction Information
- GPS created by USA DoD
 - Wanted it unjammable
 - Needed to determine how to discern different GPS satellites
- Signals Utilize CDMA (Gold Code)
 - FHSS Signal, hopping every 1 millisecc
 - 2^{1023} or $8.99 * 10^{307}$ different channels

Pseudorange Determination

- GPS Receiver must have 4 GPS satellites' pseudoranges for acquisition
- $R_r^S = \rho_r^S(t_r - t_s) - (\delta t_r - \delta t_s)c + \delta_{ion} + \delta_{tro} + \delta_{tide} + \delta_{mul} + \delta_{rel} + \varepsilon$
- $\rho_r^S(t_r, t_s) = \sqrt{(\Delta x)^2 + (\Delta y)^2 + (\Delta z)^2}$

Typical GNSS Acquisition

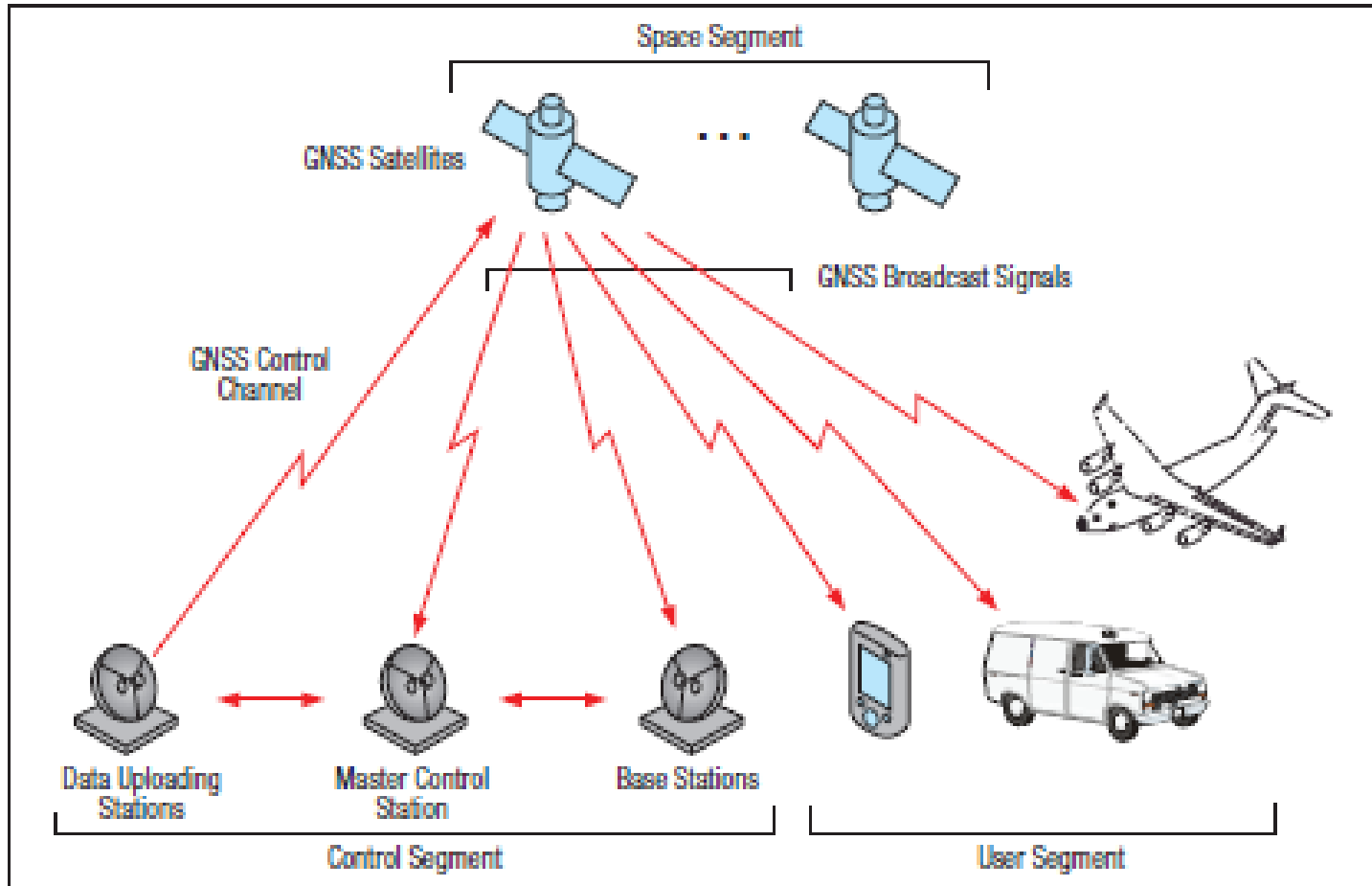

(Jeffrey, 2010)

My Role in FIREBIRD GPS

- Understand Models used and their utilization
- Understand Time Algorithms
- Identify Optimal Command and Log Sets of the GPS Card with limited data resources
 - 196 Logs
 - 84 Commands

GPS Testing



GPS Sensitivity Testing Setup

GPS Testing

- Tested
 - Receiver Sensitivity
 - Data Sheet: -122dBm
 - Empirical: -114dBm
 - Acquisition Times
 - TTFF Warm ~ 1.5 minutes
 - TTFF Cold ~ 12.5 minutes
 - Data Outputs



GPS Sensitivity Testing Setup

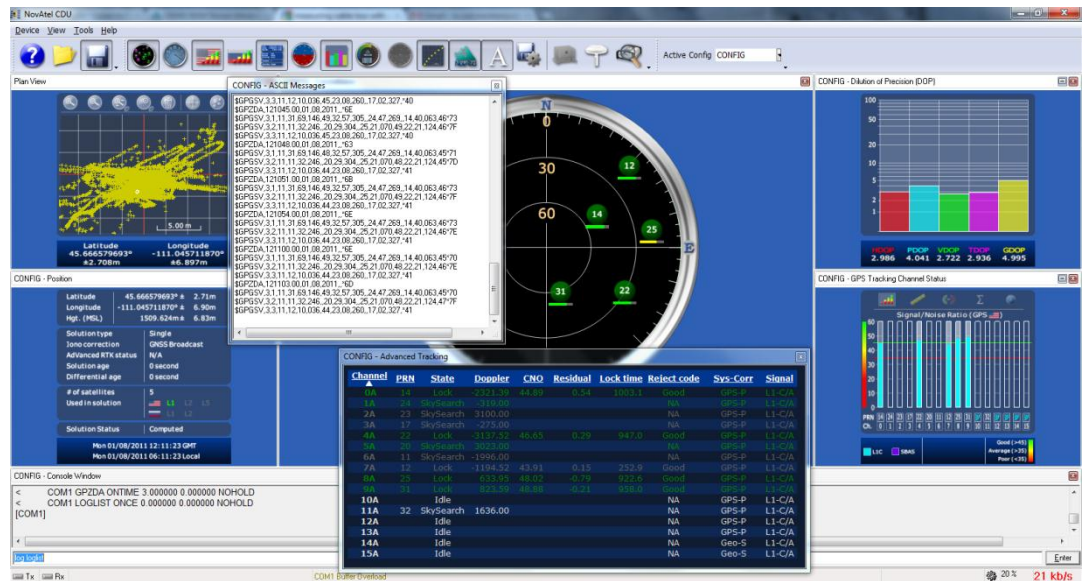

GPS Terminal Window

GPS Data Rates

- 1Mbps data rate downlink per GPS satellite into FIREBIRD GPS Receiver
 - ~5% of this data is sent to GPS Bus to be stored
- Bottleneck caused by limited capabilities of Small Satellites
- Can cause problems later with downlinking to ground station
 - Ground Station downlink is 19.2kbps
 - ~ 10minutes per pass
 - ~ 1 pass to download 1 day of GPS data

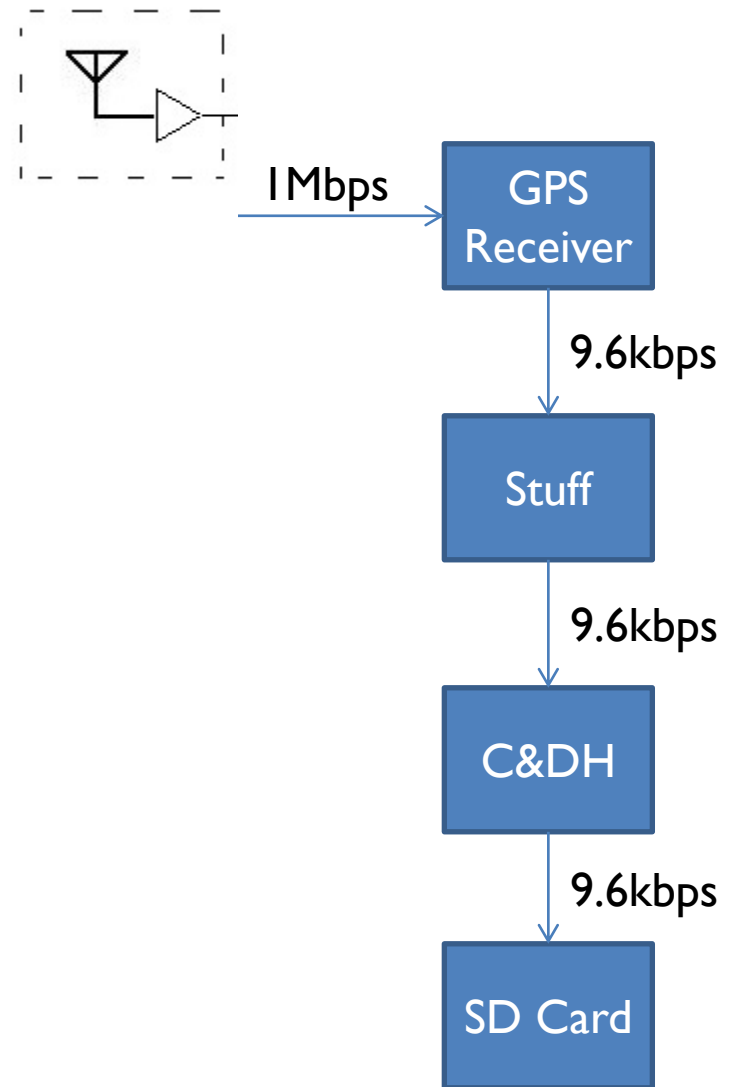

References

- Chen, L, Ong, C, Neo, C, Varadan, V.V., & Varadan, V.K. (2004). *Microwave electronics: measurement and materials characterization*. England: John Wiley & Sons.
- ETB. (2009). *Thermal expansion metals*. Retrieved from http://www.engineeringtoolbox.com/thermal-expansion-metals-d_859.html.
- Franco, S. (2002). *Design with operational amplifiers and analog integrated circuits*. New York, New York: McGraw-Hill.
- Garg, R, Bhartia, P, Bahl, I, & Iltipiboon, A. (2004). *Microwave antenna design handbook*. Norwood, MA: Artech House, Inc.
- Islam, M, Tuncer, E, & Neikirk, D. (1994). Accurate quasi-static model for schottky-contacted voltage controlled coplanar waveguide phase shifters. *Electronics Letters*, 30. Retrieved from http://weewave.mer.utexas.edu/MED_files/MED_research/CPW_stuff/R_C_CPW.html
- Jeffrey, C. (2010). *An introduction to gnss*. Calgary, Canada. Novatel, Inc.
- Kraus, J. (1986). *Radio astronomy*. Powell, OH: Cygnus-Quasar Books.
- Kraus, J., & Marhefka, R. (2003). *Antennas for all applications*. Singapore: McGraw-Hill.
- Nakar, P. (2004). *Design of a compact microstrip patch antenna for use in wireless/cellular devices*. Unpublished manuscript, Department of Electrical and Computer Engineering, Florida State University, Tallahassee, Florida. Retrieved from <http://etd.lib.fsu.edu/theses/available/etd-04102004-143656/>
- Nugent, R, Munakata, R, Chin, A, Coehlo, R, & Puig-Suari, J. (2008). The cubesat: the picosatellite standard for research and education. *American Institute of Aeronautics and Astronautics*,
- Pozar, D. (1998). *Microwave engineering*. New York, New York: John Wiley and Sons.
- Simons, R. (2001). *Coplanar waveguide circuits, components, and systems*. New York, New York: John Wiley and Sons.
- Wadell, B. (1991). *Transmission line design handbook*. Ann Arbor, MI: Artech House.
- Wolff, E., & Kaul, R. (1988). *Microwave engineering and systems applications*. New York, New York: John Wiley & Sons.



Thank You

Questions?

Acknowledgments:

SSEL Small Satellite Team
REU Faculty Members
National Science Foundation

Transmission Lines

- Max Power Transfer
 - Improper impedance match yields reflections

- Impedance

$$Z = \sqrt{\frac{R + j\omega L}{G + j\omega C}}$$

- Skin Depth(δ)

- AC travels along the surface of metallic materials

- $\delta = \sqrt{\frac{\rho}{\pi f \mu_r}}$

ρ = Bulk Resistivity
 f = Frequency
 μ_r = Relative Permeability

- 3 Skin Depths \sim 95% Transmission



Coaxial cable

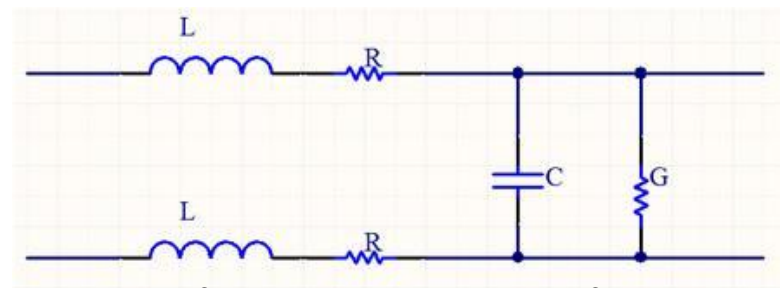

Model of transmission line at microwave frequencies

Antenna

- Reciprocity
 - Same for Transmit and Receive
- Transducer
 - Converts Electrical Energy to EM Energy
 - Works inversely for Receiving Electrical Signal
- Impedance Matcher
 - Converting 50Ω to 377Ω
- Radiation
 - Produced by Interruption of Current Flow
- Antenna Gain
 - Not Amplifier
 - Focus Energy
 - All Antennas are Dipole
- Antenna Environment
 - Environmentally Dependent

$$Z_o = \sqrt{\frac{\mu_o}{\epsilon_o}}$$

Impedance of free space

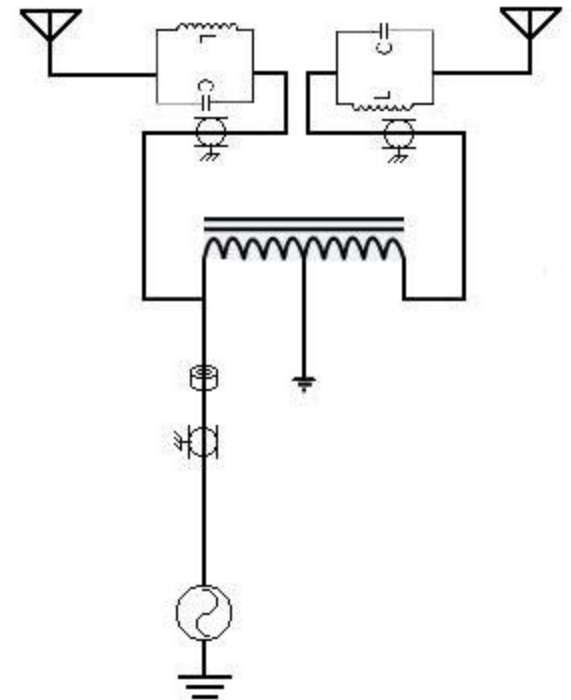

Block diagram of VHF/UHF Transmission Lines

Satellite Communications Principles

- To communicate satellites must achieve an acceptable SNR according to Friis Equation

$$SNR = \frac{P_t G_t G_r \lambda^2}{kTB(4\pi r^2)^2 L}$$

P_t = Power Arriving at Antenna

G_t = Gain of Transmit Antenna

G_r = Gain of Receive Antenna

λ = Wavelength

k = Boltzman's Constant

T = System Temperature

B = Bandwidth

r = Distance

L = Losses

- Four Components:

Signal = $P_t G_t G_r$

Noise = kTB

Loss = Transmission Line Loss, Receiver Loss, Pointing Error, Faraday Rotation

Signal Divergence = $\frac{\lambda^2}{(4\pi r^2)^2}$

- To Improve the ratio, you can alter:

- Transmit Power
- Satellite Antenna
- Ground Station Antenna
- Bandwidth
- System Temperature

Microstrip

- What is Microstrip?
 - Two conducting plates of opposite polarization with a dielectric media between them
- Physical Size determines intrinsic characteristics
 - W (or L) = $\lambda_0/2$
 - Since $\epsilon \neq 1$,
- Magnetic fields radiate through substrate

$$\lambda = \frac{\lambda_0}{\sqrt{\epsilon_{eff}}}$$

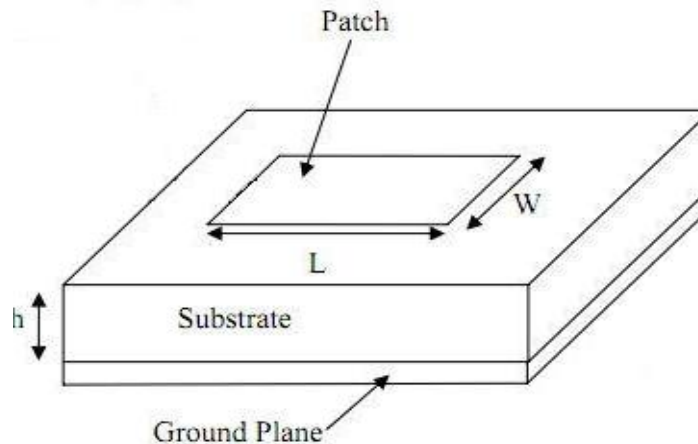
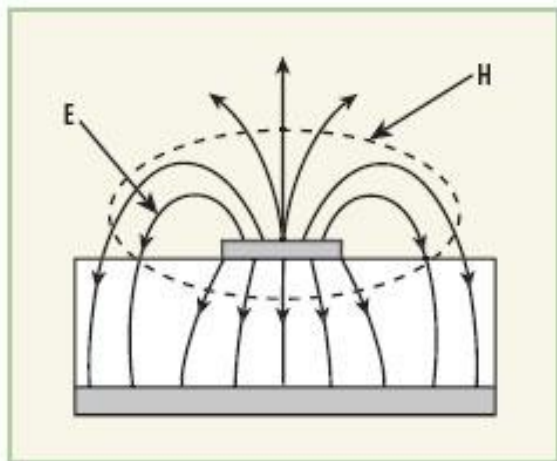

(Nakar, 2004)

Substrate Characteristics	
Material	Rogers 4003C
f	2.4015 GHz
ϵ	3.5
h	0.090"
t	0.0028" (2oz)
λ_0	4.9"
W_{ground}	2.17"
λ ($\lambda/4$)	2.6" (0.65")
δ	0.000052"

Coplanar Waveguide (CPW)

- What is Coplanar Waveguide?
 - Coplanar transmission line with a center conductor, surrounded by ground plane with separation between the two
 - Essentially, Coplanar Coaxial Cable

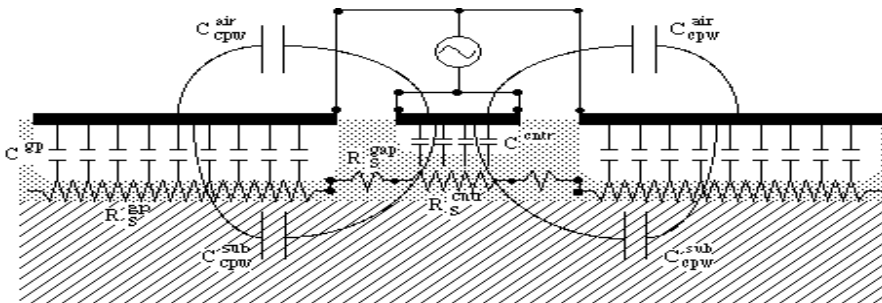
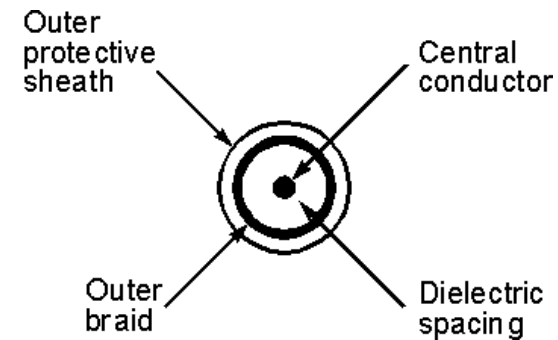

http://weewave.mer.utexas.edu/MED_files/MED_research/CPW_stuff/R_C_CPW.html

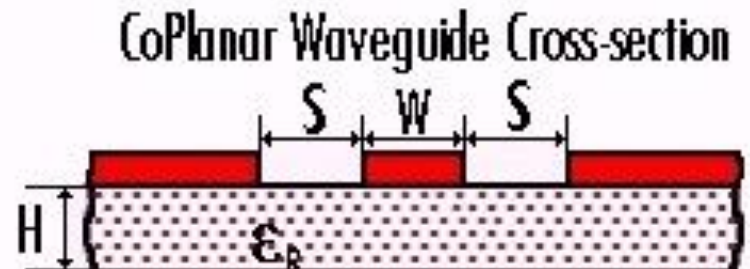

<http://www.microwaves101.com/encyclopedia/coplanarwaveguide.cfm>